

4

3

2

1

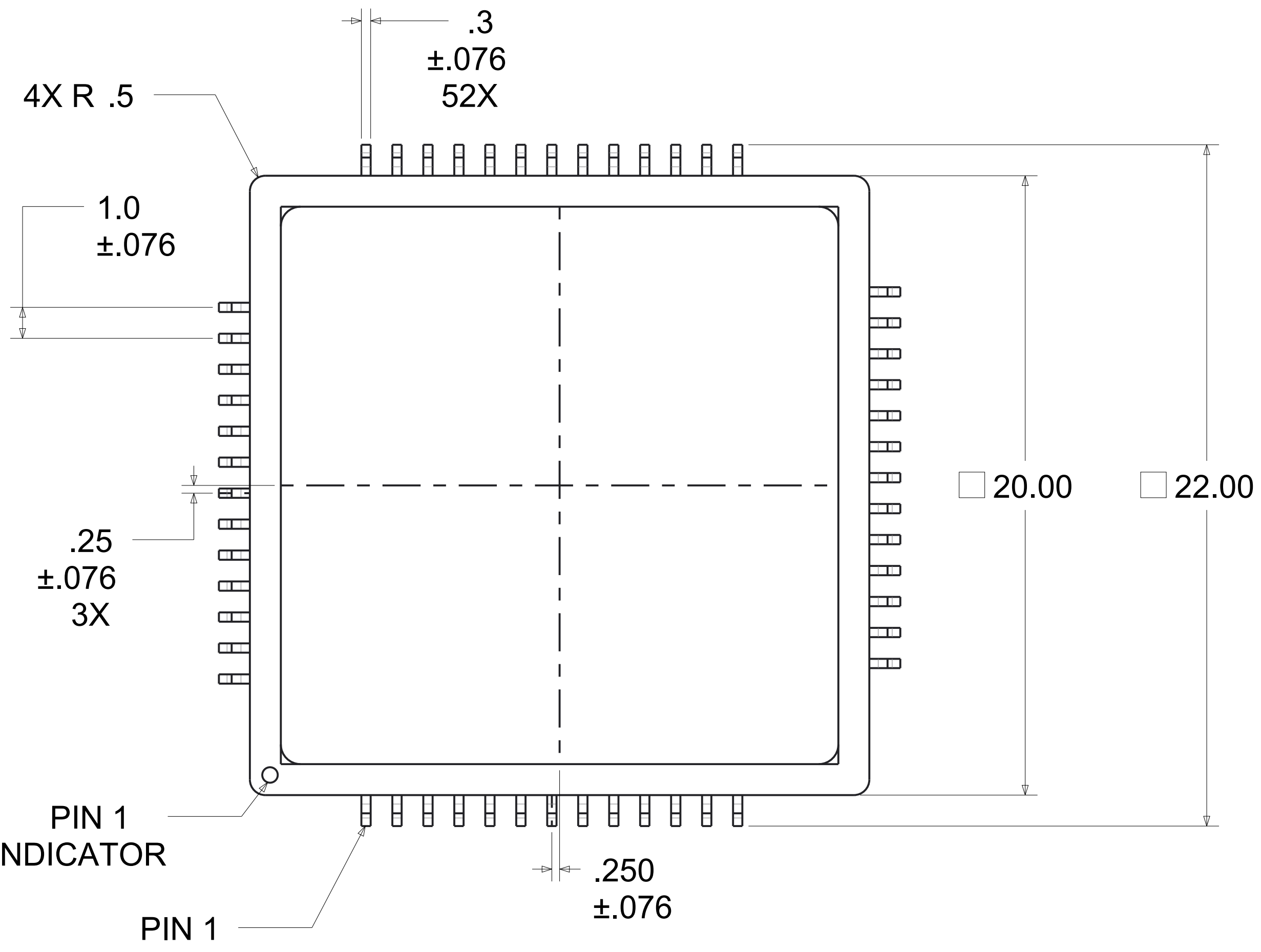

RECOMMENDED PAD LAYOUT

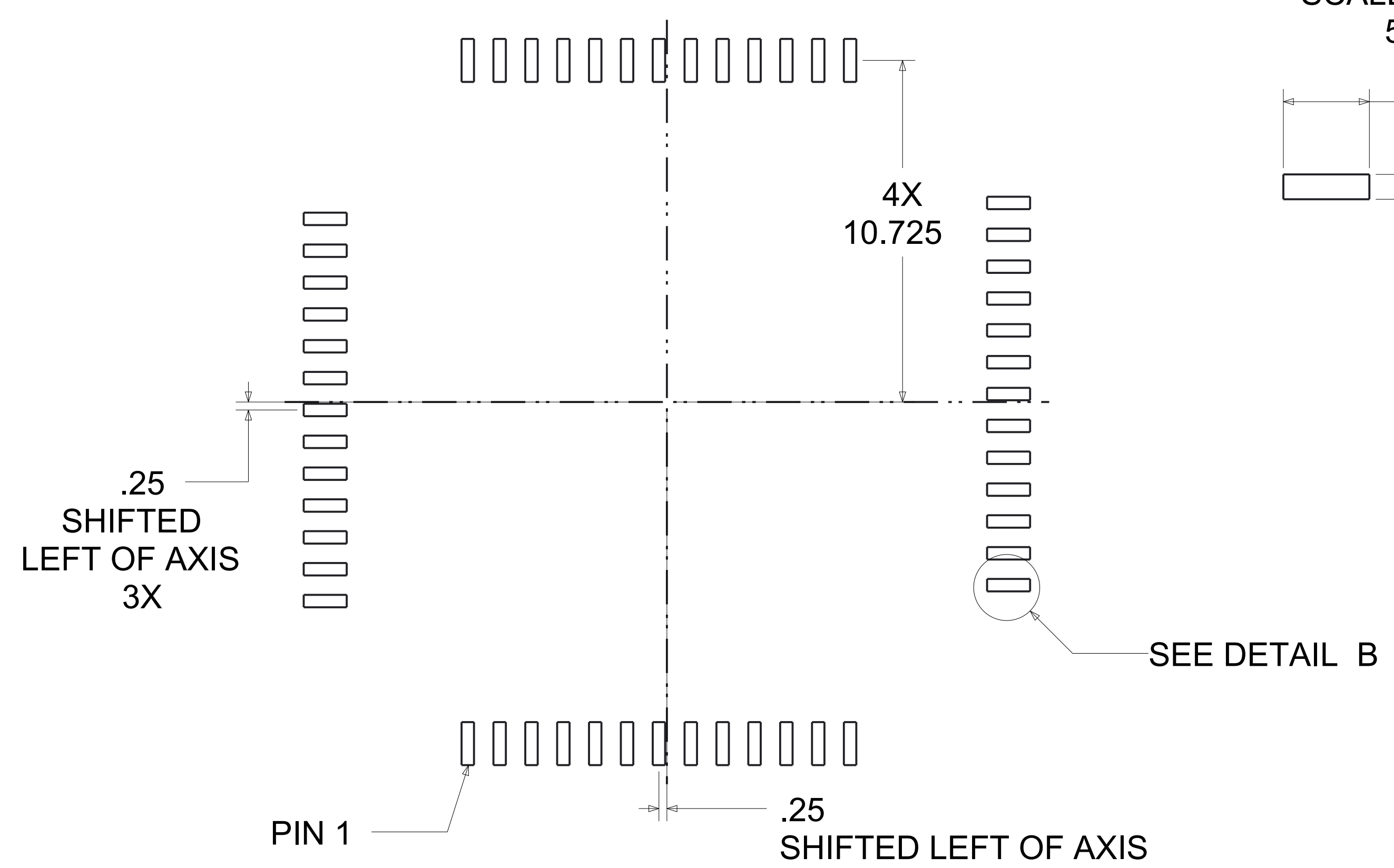

DETAIL B SCALE 16.000 52X

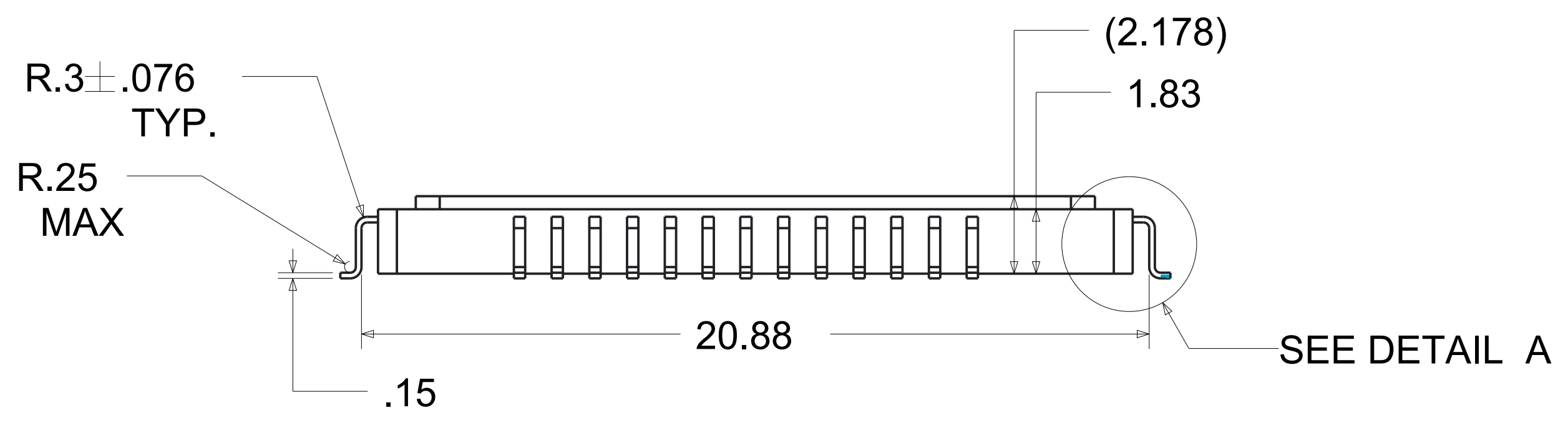
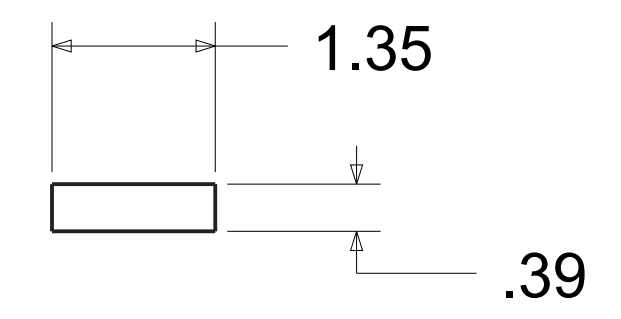

DETAIL A SCALE 20.000

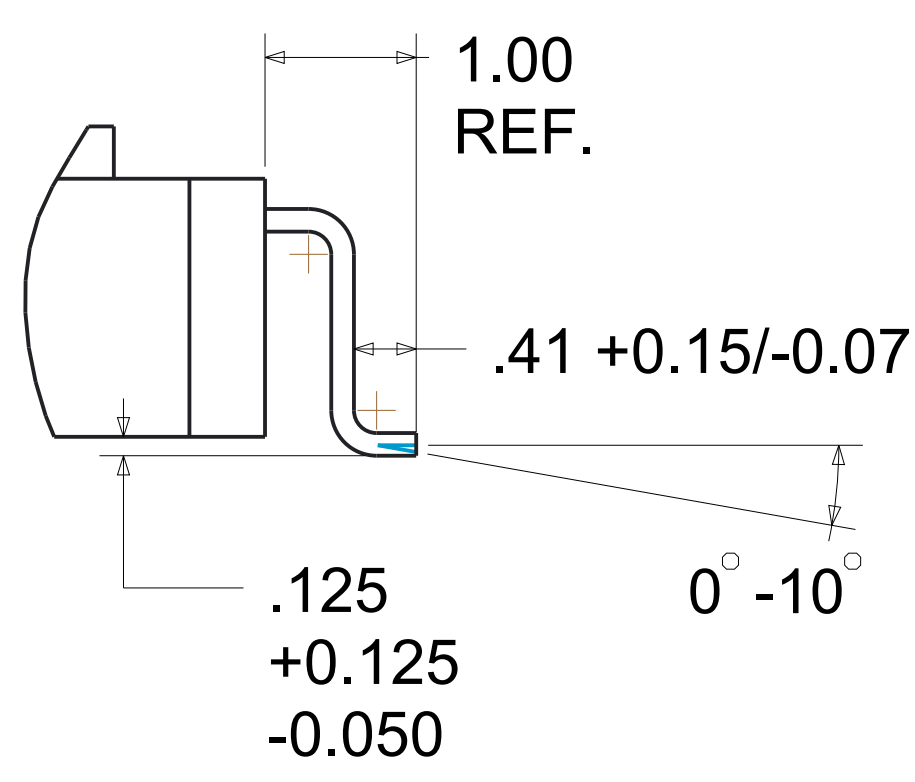

TOP ISOMETRIC VIEW SCALE 6.000

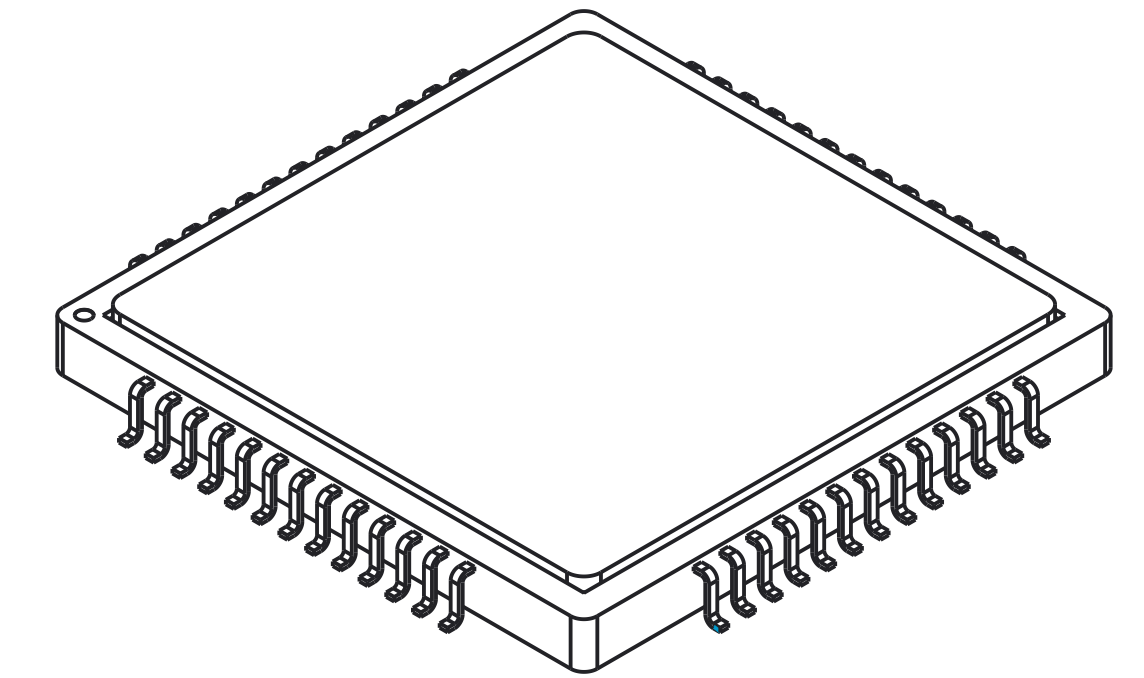

NOTES:

- 1. DIMENSIONS ARE IN MM [IN].
- 2. UNLESS OTHERWISE NOTED, TOLERANCES ARE ±.25 [.010].
- 3. ANGLE TOLERANCES ARE ±3°.
- 4. DRAWING SCALE IS 8.000.
- 5. ALL LEADS TO BE COPLANAR WITHIN 0.1 [.004].

		TITLE: 52 LEAD, 20MMx20MM, POWER QUAD				MODEL: PQ	
		SUBJECT: MECHANICAL DRAWING					
ENGINEER: EAS	DRAWN BY: EAS	DCA: 18628	SH. 1	OF 1	FILENAME: PQ	REV: B	DATE: 18DEC18

4

3

2

1