

4

3

2

1

D

D

C

C

B

B

A

A

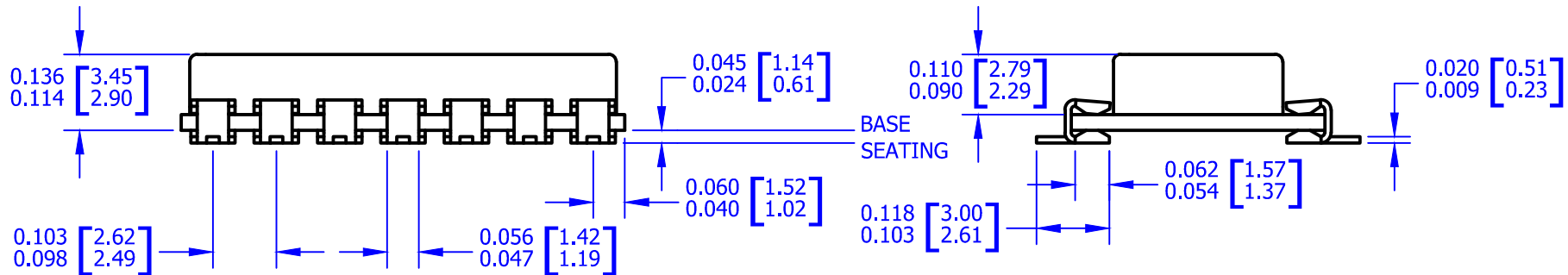
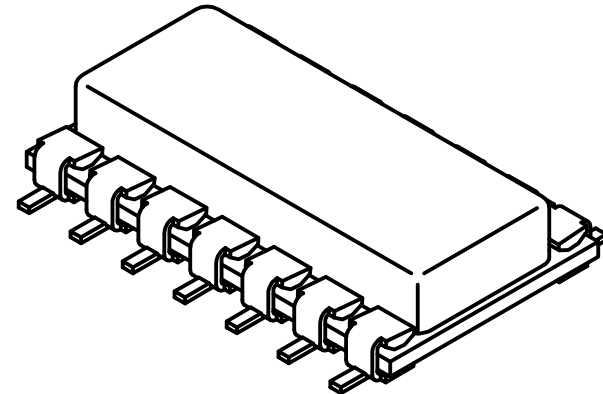
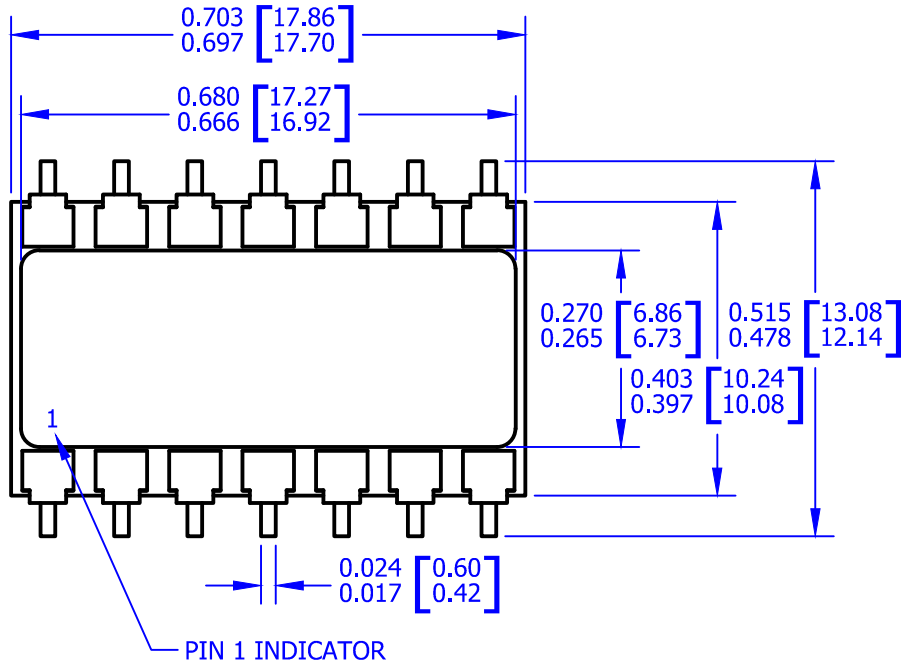

NOTES:

1. Dimensions are inches & [millimeters].
2. Bracketed alternate units are for reference only.
3. Pins: Phosphor bronze, Sn/Ag 96/4 solder dipped.
4. Material: Alumina Ceramic substrate and cover.
5. Package weight: 0.049 oz. [1.382 g].
6. Epoxy sealed, non-hermetic package.

TOLERANCES - UNLESS OTHERWISE SPECIFIED
.XX = ±0.01 [0.254]
.XXX = ±0.005 [0.127]
ANG. = ±5°



TITLE:	14-pin DIP, WIDE SMT				MODEL:	GE	
SUBJECT:	PACKAGE OUTLINE				ENGINEER:	K.GREG	DATE:
DRAWN BY:	J.FAY	DCA:	16380	SH. OF:	1	1	REV:
FILENAME:	GE		REV:	E		DATE:	22SEP16

4

3

2

1