

4

3

2

1

D

D

C

C

B

B

A

A

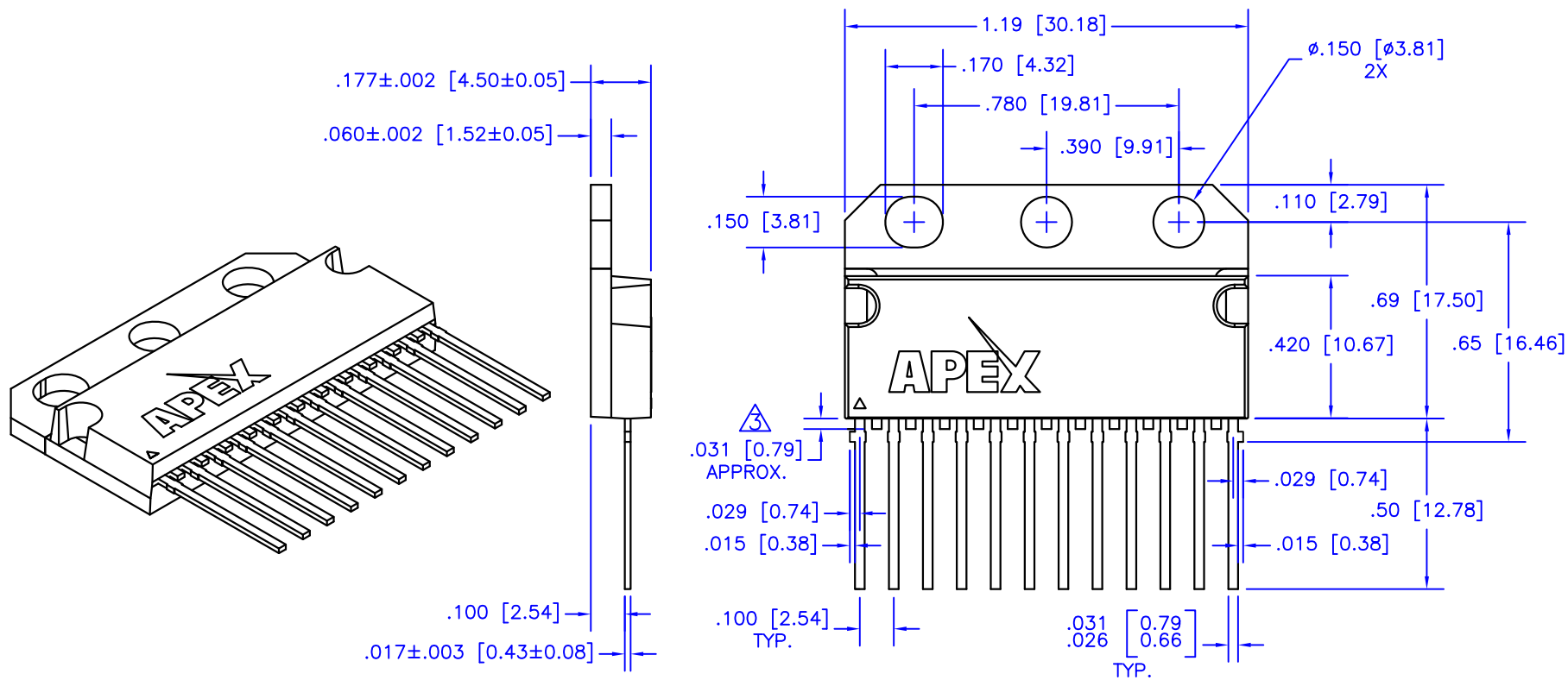
**NOTES:**

1. Dimensions are inches & [mm].
2. Triangle denotes pin 1.
3. Assemble with care to avoid solder bridging across stub pins.
4. Plastic may be present between leads and stub pins.
5. Pins & finish: Nickel/Palladium plated CDA19400 copper.
6. Mold compound: Sumitomo EME6300HX
7. Package weight: 0.29 oz [8.3 g]

TOLERANCES - UNLESS OTHERWISE SPECIFIED

.XX = ±.01 [.254]

.XXX = ±.005 [.127]

ANG. = ±5°



TITLE: 12-pin MOLDDED PLASTIC SIP

SUBJECT: PACKAGE OUTLINE

ENGINEER: D-M

DRAWN BY: R.MOR

DCA: 13228

SH. OF 1 1

MODEL:

EU

FILENAME: EU

REV: D

DATE: 29MAY13

4

3

2

1