

## Evaluation Kit

### INTRODUCTION

This easy to use kit provides a platform with good circuit board layout and grounding to evaluate Power Amplifier PA165. With additional prototype area, it is flexible enough to analyze a multitude of standard or proprietary circuit configurations. All components are provided with the kit. The evaluation kit consists of a PA165, which is mounted on a daughter board along with input protection diodes, power supply bypass capacitors, and compensation capacitors.

The Evaluation kit also consists of few passive components and connectors that should be soldered on the board. These components are not presoldered so as to provide flexibility to the user for changing amplifier configuration as per the users application.

**Figure 1: EK74 Circuit Configuration Diagram**

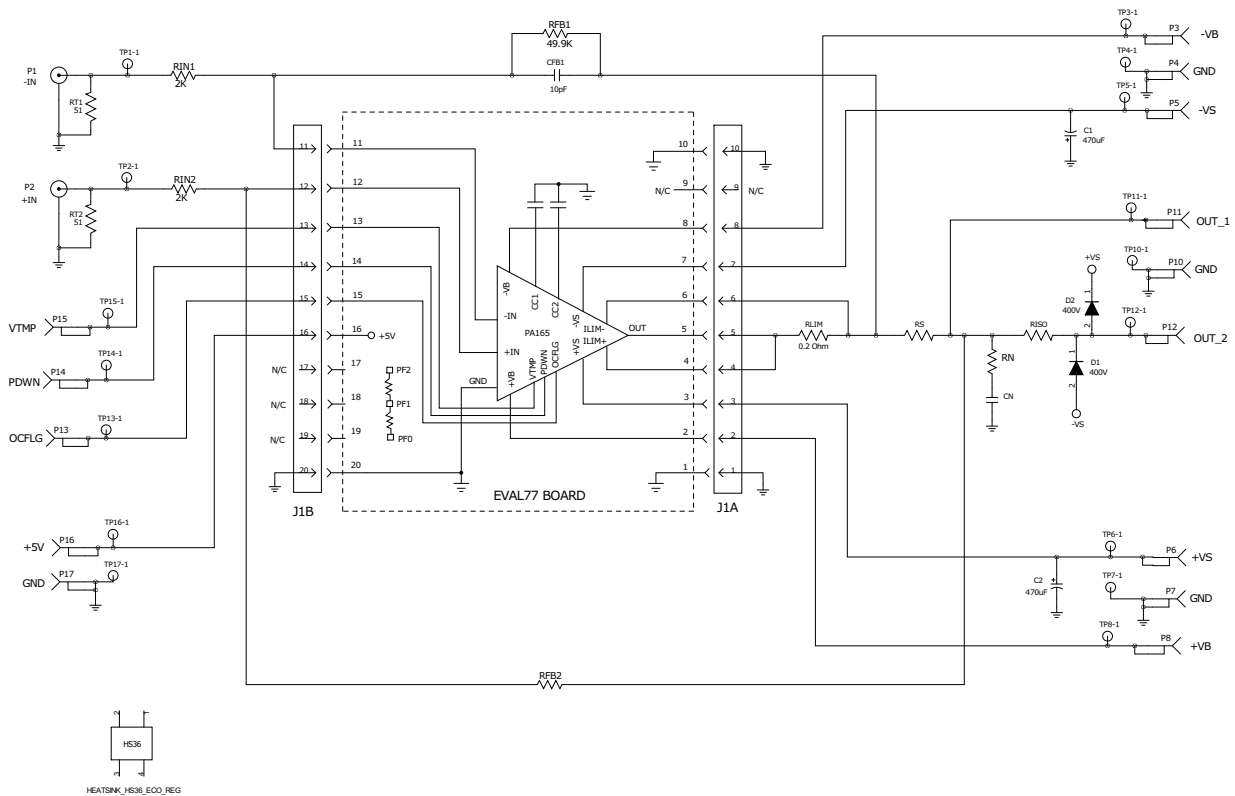
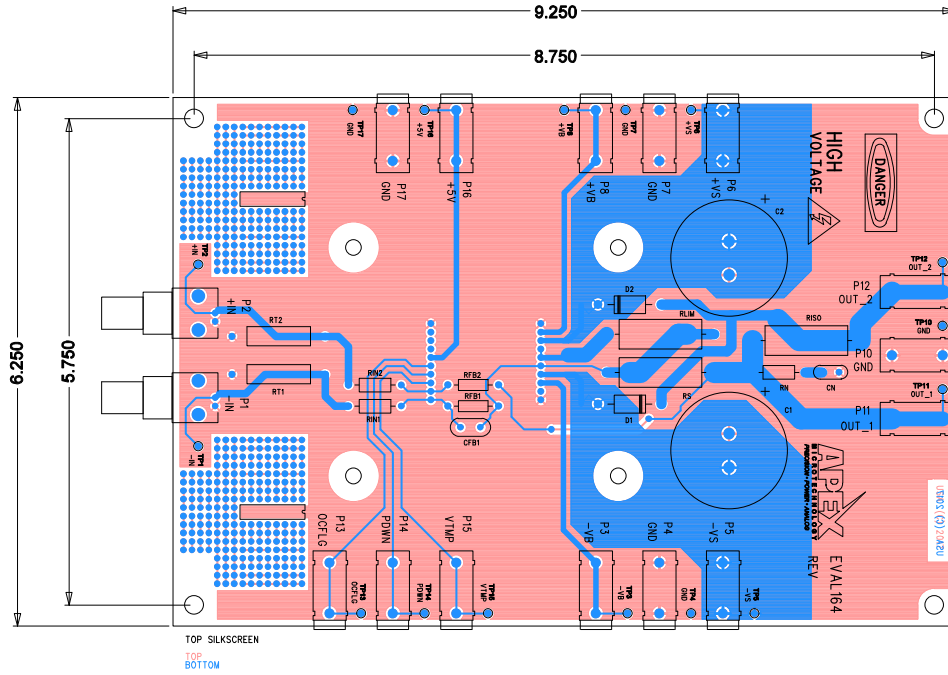
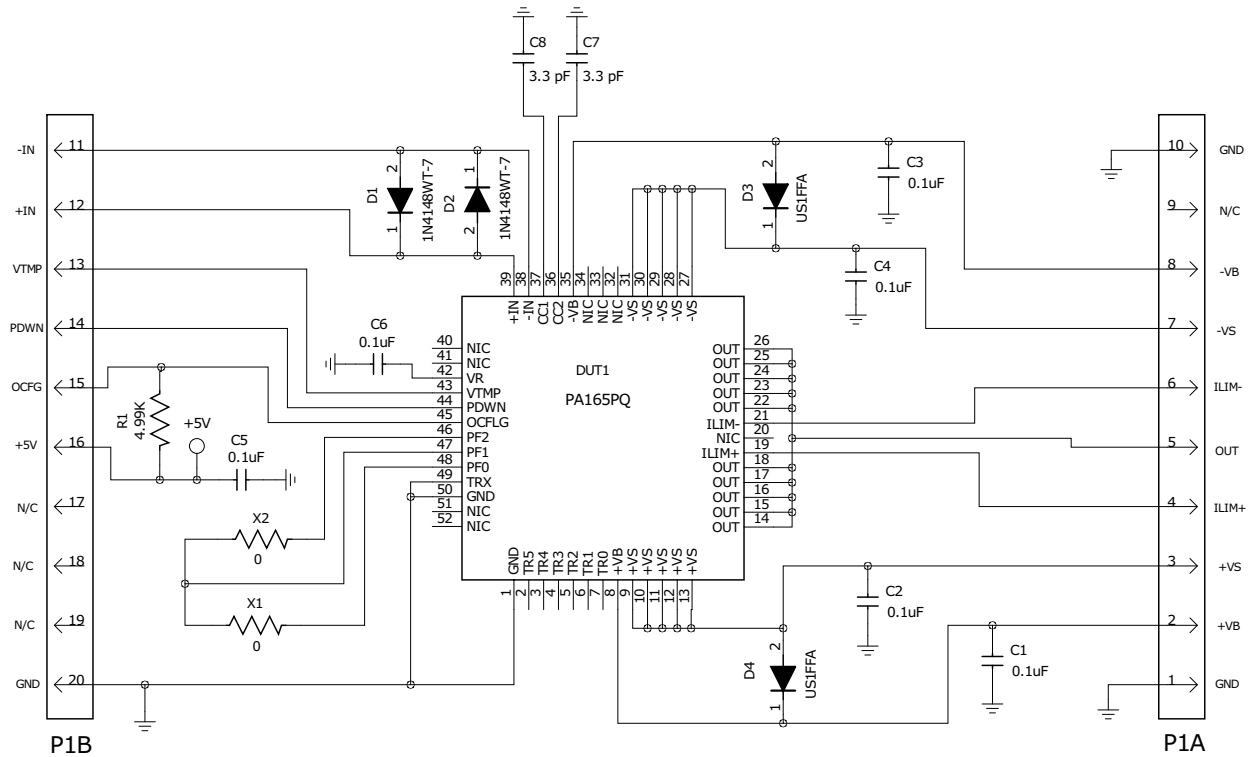

Figure 2: EVAL 164 PCB Layout



VIEWED FROM THE TOP SIDE

Figure 3: EVAL 77 Circuit Configuration Diagram



**PARTS LIST**

Reference	Manufacturer Part #	Description	Qty
<b><u>Resistors</u></b>			
RT1, RT2	PR03000205109JAC00	51 $\Omega$ , 3W, 5%	2
RIN, RIN2	CMF552K0000FHEB	2k $\Omega$ , 1/2W, 1%	2
RFB1	CMF5549K900FHEB	49.9k $\Omega$ , 1/2W, 1%	1
RLIM	13FR200E	0.2 $\Omega$ , 3W, 1%	1
<b><u>Printed Circuit Board</u></b>			
EVAL 164		Printed Circuit Board	1
<b><u>Capacitors</u></b>			
C1, C2	KMH450VN471M35X50T2	ALUM, 470 $\mu$ F, 450V	2
<b><u>Diodes</u></b>			
D1, D2	MUR440G	Switching Diode	2
<b><u>Hardware</u></b>			
	EK91-1	Daughter Evaluation board for PA165	1
	SSW-110-01-T-S	Socket, 10 Pin	2
	146510CJ	BNC Connector, PC Mount	2
	91735A190	Screw, Panhead, #8 X 0.25"	4
	91249A126	4-40 Thread Size, 1-1/2" Long	4
	94758A101	18-9 Stainless Steel Flange Nut, 4-40	4
	2221	Standoff, HEX, #8X 2.00"	4
	571-0100	Banana Jacks	14
	5001	Test Point, PC mini	20

## BEFORE YOU GET STARTED

- All Apex amplifiers should be handled using proper ESD precautions.
- Always use the heat sink and thermal washers included in this kit.
- Always use adequate power supply bypassing.
- Do not change the connections while the circuit is powered.
- Initially set all power supplies to the minimum operation levels allowed in the device data sheet.
- Check for oscillations.
- Please refer to Application Note, AN01 for general operating considerations.

## ASSEMBLY

During the assembly, please refer to the circuit schematics, assembly drawings, and the data sheet of the part being used on the evaluation kit.

1. Note, a pre-assembled EK91-1 board is provided which contains the PA165 power amplifier and a heat sink attached to it.
2. All the components are mounted on the components side the EVAL 164 board, except the 10 pin socket. Mount two 10 pin sockets on the DUT side of the board.
3. After the sockets have been soldered, solder smaller components like resistors, capacitors, and diodes on the component side of the board.
4. Components for RT1, RT2, RIN1, RIN2, RFB1, D1, D2, RLIM, C1, and C2 are provided. These should be soldered on EVAL 164 PC board on the component side. Ensure that the orientation of the capacitors C1 and C2 match the circuit drawing.
5. To use the amplifiers in a simple inverting or non-inverting configuration, short RS resistor with a bus wire. RS resistor should only be used when using the amplifiers in a Howland current pump configuration.
6. Mount the BNC connectors, Banana jack connectors and test points on the component side of EVAL 164.
7. Once all the components are mounted on EVAL 164, please mount on the EK91-1 into the socket on EVAL 164 on the DUT side.
8. After mounting the EK91-1 on EVAL 164, use 91249A126 (4-40 thread, 1.5" long) screws through EVAL 164 to hold EK91-1 board. 4-40 flange nuts are provided for these screws.
9. #8 hex standoffs are also provided with the kit. Install the #8 x 0.25" screws (91735A190), provided with the kit, from the component side. Attach the standoffs to these screws on the corners of the board.

## TEST ASSEMBLY

### EQUIPMENT NEEDED

1. Power Supply
2. Function Generator
3. Oscilloscope
4. Proper heatsinking system (if operating at high current).

### TEST SETUP

Connect the power supply to  $+V_S$  and  $-V_S$  ports. If you wish to use boost supply, connect boost voltage supplies to  $+V_B$  and  $-V_B$  ports. Otherwise, short  $+V_S$  to  $+V_B$  and  $-V_S$  to  $-V_B$ . Refer to product data sheet for voltage specifications. Connect the BNC cable from the function generator to either P1 port for inverting configuration or to P2 for non-inverting configuration. Connect a 5V DC supply to P16 port for over current flag.

Do not plug in EK91-1 board yet. First power on the input signal and power supplies. Measure voltages on all pins on J1A and J1B on the DUT side to ensure that there is no short and to check if all the pins read correct voltages.

Now, mount the EK91-1 on EVAL 164. If connecting a resistor load, connect between ports P11 and P10. If a snubber circuit is connected, connect a reactive load between P12 and P10. Input and output waveforms can be checked on an Oscilloscope by connecting it to the test points mounted on the board. Begin the test with minimum values of input and supply voltages.

**Figure 4: EK74 Build**

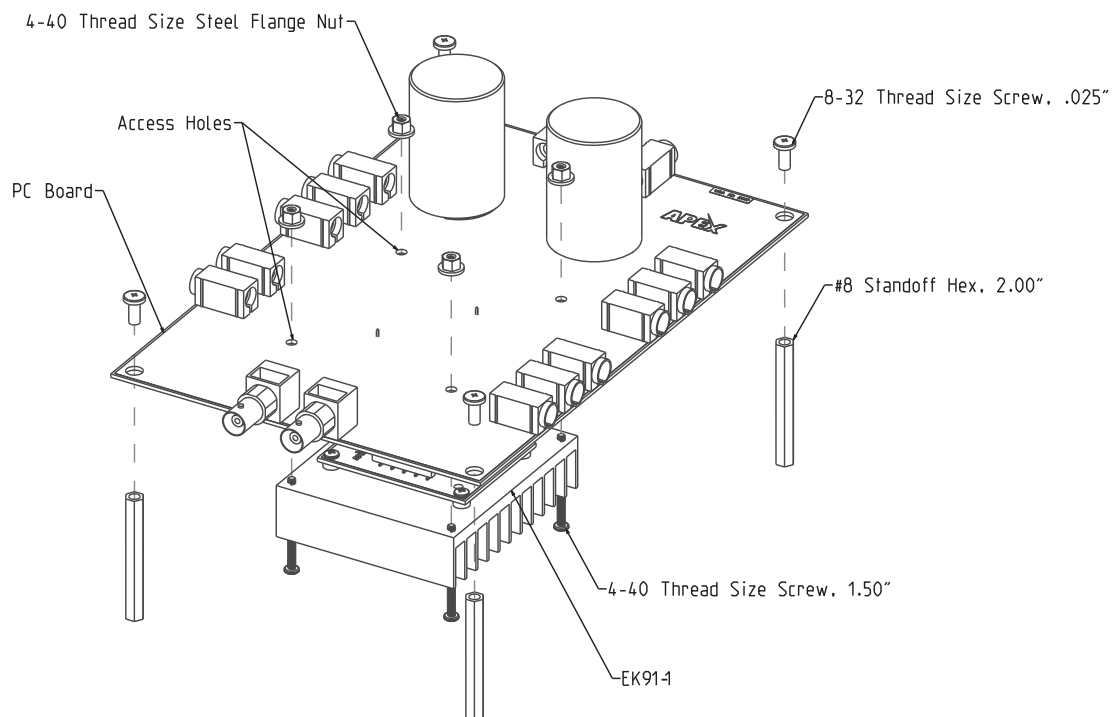
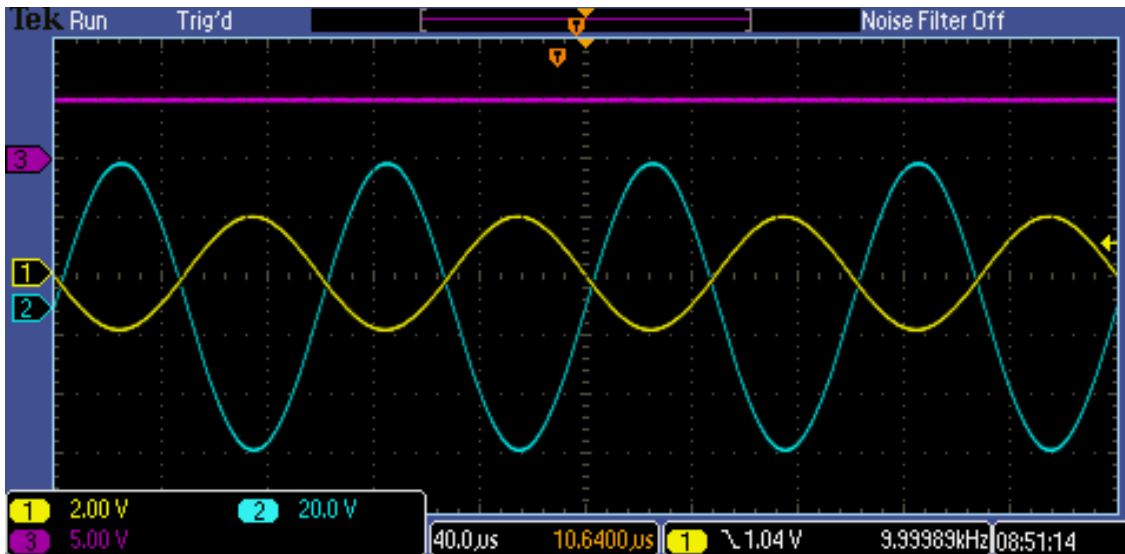

Figure 5 and 6 show the input, output and over current flag waveforms when a PA 165 is evaluated using the EK74 evaluation kit. The yellow waveform (channel 1) represents an input signal of  $4V_{p-p}$  and cyan waveform (channel 2) represents an output signal of  $100V_{p-p}$ . Magenta waveform (channel 3) represents the over current flag.

During normal operation, the over current flag will remain high as shown in figure 5. When the amplifier starts operating in current limit mode, the over current flag becomes low as shown in figure 6.

**Figure 5: Normal Operation**



**Figure 6: Current Limit Operation**

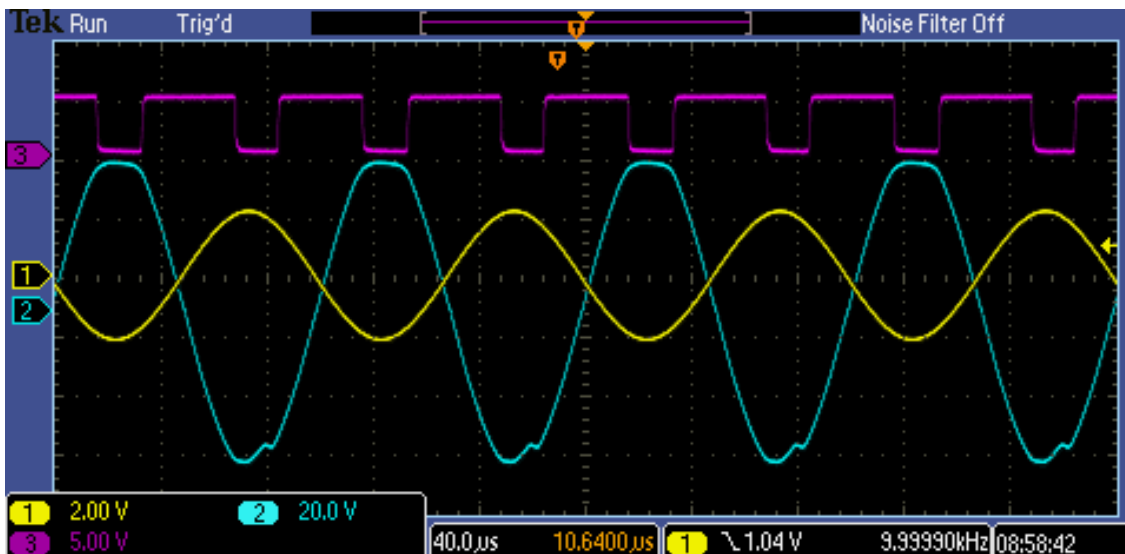

---

## **NEED TECHNICAL HELP? CONTACT APEX SUPPORT!**

For all Apex Microtechnology product questions and inquiries, call toll free 800-546-2739 in North America. For inquiries via email, please contact [apex.support@apexanalog.com](mailto:apex.support@apexanalog.com). International customers can also request support by contacting their local Apex Microtechnology Sales Representative. To find the one nearest to you, go to [www.apexanalog.com](http://www.apexanalog.com)

---

### IMPORTANT NOTICE

Apex Microtechnology, Inc. has made every effort to insure the accuracy of the content contained in this document. However, the information is subject to change without notice and is provided "AS IS" without warranty of any kind (expressed or implied). Apex Microtechnology reserves the right to make changes without further notice to any specifications or products mentioned herein to improve reliability. This document is the property of Apex Microtechnology and by furnishing this information, Apex Microtechnology grants no license, expressed or implied under any patents, mask work rights, copyrights, trademarks, trade secrets or other intellectual property rights. Apex Microtechnology owns the copyrights associated with the information contained herein and gives consent for copies to be made of the information only for use within your organization with respect to Apex Microtechnology integrated circuits or other products of Apex Microtechnology. This consent does not extend to other copying such as copying for general distribution, advertising or promotional purposes, or for creating any work for resale.

APEX MICROTECHNOLOGY PRODUCTS ARE NOT DESIGNED, AUTHORIZED OR WARRANTED TO BE SUITABLE FOR USE IN PRODUCTS USED FOR LIFE SUPPORT, AUTOMOTIVE SAFETY, SECURITY DEVICES, OR OTHER CRITICAL APPLICATIONS. PRODUCTS IN SUCH APPLICATIONS ARE UNDERSTOOD TO BE FULLY AT THE CUSTOMER OR THE CUSTOMER'S RISK.

Apex Microtechnology, Apex and Apex Precision Power are trademarks of Apex Microtechnology, Inc. All other corporate names noted herein may be trademarks of their respective holders.