

PROPER COMPENSATION TECHNIQUES WILL LET THE IMPROVED-HOWLAND AND FLOATING-LOAD CURRENT SOURCES PERFORM UP TO PAR.

TAME THOSE VERSATILE CURRENT-SOURCE CIRCUITS

One task op amps are often called upon to perform is to produce controlled-current outputs. Over the years, designers have devised a number of circuit configurations to do the job such as current sources, current pumps, voltage-to-current converters, voltage-controlled current sources (VCCS), current-to-current converters, or current-controlled current sources (CCCS). In every case, the idea is to develop a precise current output emulating an ideal current source with infinite source impedance.

But unless designers know how to properly analyze and compensate these circuits, they may be disappointed with their results. To that end, this article shows how to design two basic forms of current-output circuits: the Improved Howland current pump for driving grounded loads, and the floating-load configuration.

A common application of current sources is torque control of brush-type dc motors, such as reel motors for tape machines. Torque in these kinds of motors is directly proportional to current. Other applications include motor-control servo loops, where current drive reduces the phase lag due to motor inductance and simplifies loop stabilization. Magnetic deflection circuits, as well as coil and solenoid drive applications, also typically require current sources.

Although the original Howland current pump has been given adequate treatment in many texts, the Improved Howland circuit is usually only given a cursory handling. Despite this fact, most modern current-output circuits, especially those using power op amps, have resorted to the Improved Howland.

Whether it's a bridge circuit, or if a load must be grounded, the Improved Howland is required (*Fig. 1*). The circuit can be configured for inverting or noninverting operation and should always be considered a voltage-controlled voltage source. That's because there are too many restrictions (concerning input-resistor impedance considerations) to easily use the Improved Howland with a current input.

The simplified gain equation of the Improved Howland is usually accompanied with the recommendation to match R_2 to R_4 , and R_1 to R_3 , which isn't really correct. More knowledgeable texts recommend the ratio:

$$R_1/R_3 = R_2/(R_4 + R_5)$$

which is still only a better approximation. But the circuit is particularly sensitive to errors in this matching; the simple equation doesn't help a designer evaluate

JERRY STEELE and TIM GREEN
Apex Microtechnology Corp.,
5980 N. Shannon Road,
Tucson, AZ 85741; (602) 690-8600.

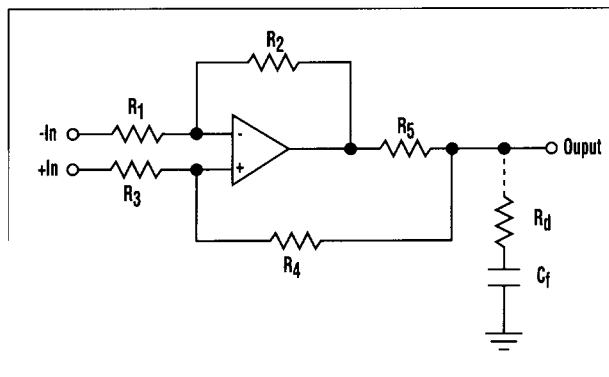

1. ACTING AS A TRUE current source, the Improved-Howland current pump achieves its high output impedance by bootstrapping current-sense resistor R_5 . Frequency compensation is supplied by R_d and C_f .

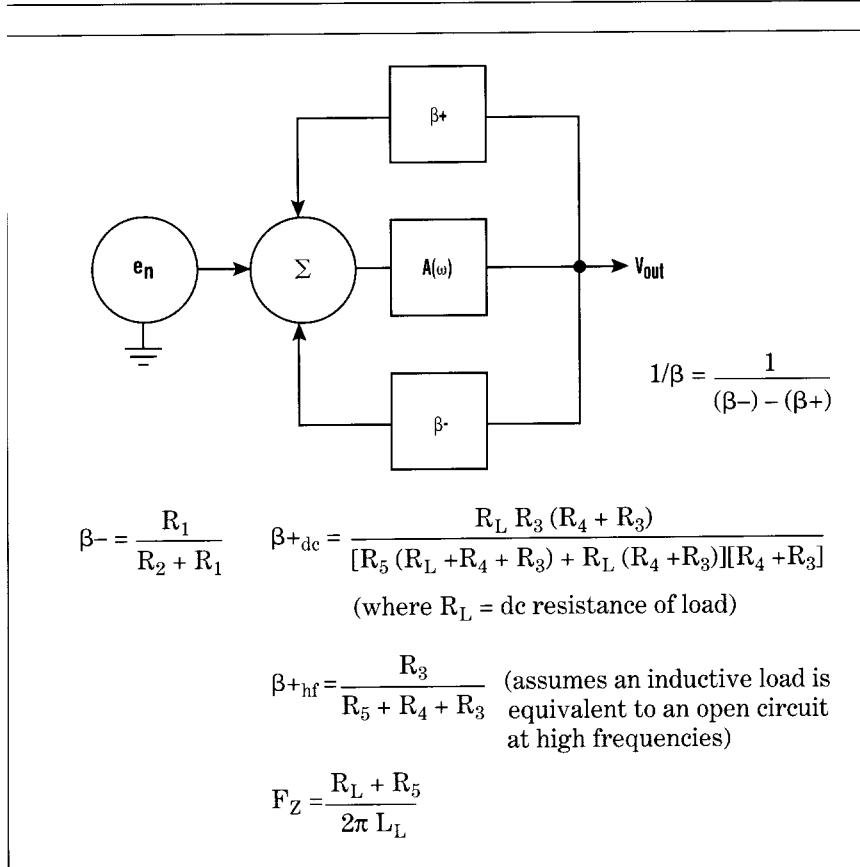

3. WHEN PERFORMING STABILITY analysis on the improved-Howland circuit, the equations reveal that the positive feedback path ($\beta+$) contains frequency-dependent terms. The load is considered part of the positive feedback path.

circuit (Fig. 2).

To simplify the equations, this example is based on an inverting input. The separate equations are shown in the figure and can be individually solved and combined to evaluate the effect of varying any resistor values and tolerances. Keep in mind that best accuracy coincides with maximum output impedance, as previously discussed.

It's important to evaluate the accuracy of an actual breadboard circuit at several output and load values. This will reveal errors due to degraded output impedance, which becomes obvious only when the load is varied. Whether or not trimpots will be necessary depends on the actual accuracy requirements of any given circuit.

To show the effects of resistor mismatch and variation in loading, a high-accuracy power op amp, PA07, was set up with 10-k Ω , 0.1% resistors in all locations except for the current-sense resistor, which was 1.0 Ω ,

1.0%. An input signal of 100 mV was applied and the current outputs were measured for 0-, 12-, and 100- Ω loads (see the table). The second and third columns of the table reflect results of a 1% error for one resistor. The error was simulated by putting a 100- Ω resistor in series with it. Because R_2 and R_3 had identical effects, the result is shown together. The same holds true for R_4 and R_1 .

The results indicate that even a 1% error in resistor values can be devastating to accuracy in the Improved Howland circuit. Note that the current appeared to be accurate into a short in all cases, and errors only appeared as loading was varied.

The Improved Howland circuit can also be analyzed using Bode plots and examining the rate-of-closure of

feedback response versus the amplifier's A_{OL} response. Figure 3 depicts the Howland as a gain block with positive and negative feedback paths that sum to one net feedback. Obviously, the feedback must be negative (or within about 40° of negative) to be stable. The alpha path is disregarded for stability analysis because the concern isn't with input signals, but rather with feedback response (although this assumes low driving impedance from the source).

Rate-of-closure techniques require calculating β , or attenuation, for each feedback path and plotting the response on the A_{OL} graph as $1/\beta$. For the Howland, $\beta-$ should be calculated first because it's the simplest feedback path and will have no frequency-dependent terms.

To calculate $\beta+$, the load should be considered as part of the positive feedback path. Since inductive loads are the only ones to give stability problems, we'll only consider that case. Calculate separately, as shown in Figure 3, the $\beta+$ for dc (inductance simplified to a short in series with inductor resistance), $\beta+$ for high frequency (inductor open), and the frequency breakpoint.

At any given frequency, calculate the resultant feedback factor ($\beta-$) - ($\beta+$); then take the inverse and convert to decibels. On the amplifier's A_{OL} graph, mark the points indicating the dc gain, the breakpoint, and the high-frequency gain (Fig. 4). The

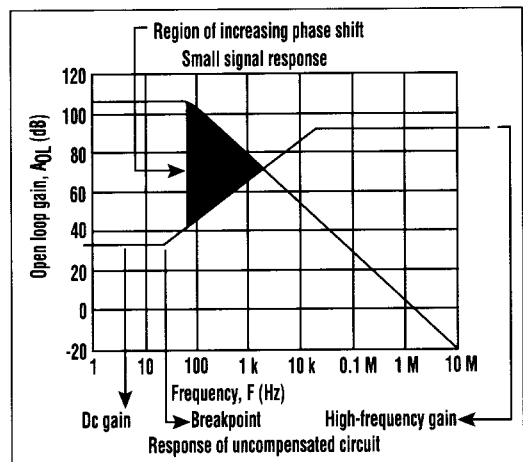

4. PLOTTING THE INVERSE of the feedback factor $[1/(\beta-) - (\beta+)]$ on the amplifier's A_{OL} graph gives the designer information about three important points: the circuit's dc gain, breakpoint, and high-frequency gain.

dc gain increases at the breakpoint by 20 dB/decade until it intersects the high frequency gain.

The region where the two responses are closing together must be compensated. In general, if the region is kept to within one frequency decade, phase shift will be within reasonable margins. Plotted graphically, the compensating response should give a flat feedback response approximately 20 dB higher than the dc gain. The response should have a corner frequency equal to or lower than the frequency at which the initial feedback breaks upward (Fig. 5). Basically, two feedback paths are plotted. The path corresponding to the lowest gain will be the dominant path.

Compensate the circuit with a series R-C combination across the inductive load to ground, as shown in Figure 1. This puts a stop in the response of the positive feedback. The resistor R_d , which is calculated according to the equation shown in Figure 5, determines and flattens the ultimate high frequency gain. Once R_d is determined, use the desired break frequency of the alternate feedback path to calculate the required C_f value (Fig. 5, again).

As mentioned earlier, current-output configurations are often used in magnetic deflection. These applications have strict requirements on the bandwidth and speed of the circuits used. The resultant bandwidth of any current-output circuit can be determined by the finalized rate-of-closure graph. At the point where the main feedback intersects the compensation feedback, the circuit begins to lose control of the load's cur-

rent. In the case of Figure 5, the graph predicts a bandwidth of approximately 500 Hz.

Rate-of-closure methods will also reveal that once properly compensated, neither the floating-load configuration (discussed later) or the Improved Howland circuit hold any advantage over each other. However, the floating-load type can be run at lower effective gain (down to unity) with some bandwidth improvement. Wide bandwidth will be easier to achieve as the load inductance is reduced and current-sense resistor values are raised.

Ultimately, any high-speed current source with inductive loading will have to be empirically trimmed to achieve the best transient response. The compensation techniques discussed here will ensure a stable starting point. From there, it will be found that raising R_d 's value will improve transient performance. Capacitor C_f will have relatively little effect once it's raised above the minimum value necessary for stability.

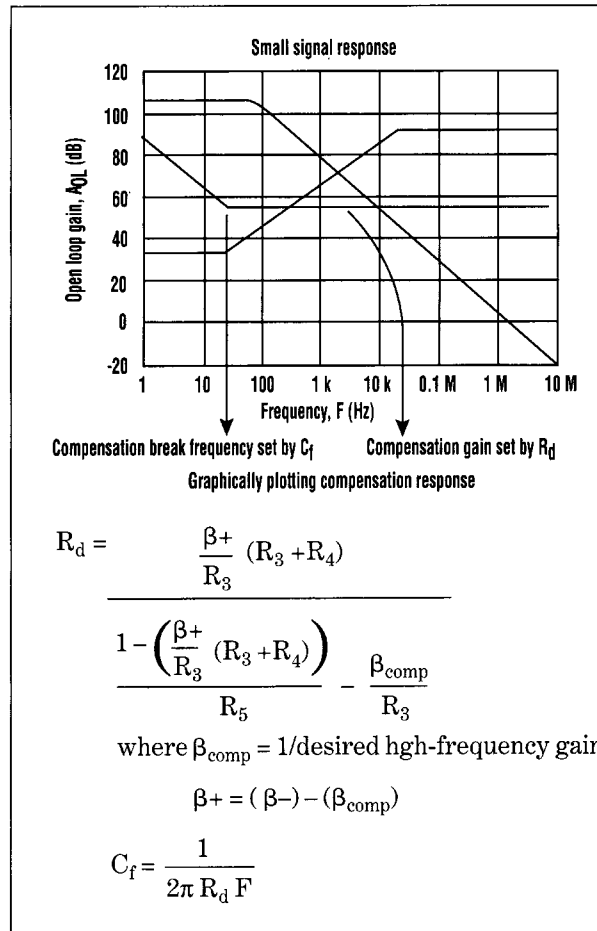

5. THE COMPENSATING response for the Improved-Howland circuit should exhibit a flat feedback response approximately 20 dB higher than the circuit's dc gain. Also, the compensating response should have a corner frequency equal to or lower than initial feedback's breakpoint.

When using either circuit at wide bandwidths, don't fail to consider the inductive characteristics of the current-sense resistor. These resistors often have low values and will dissi-

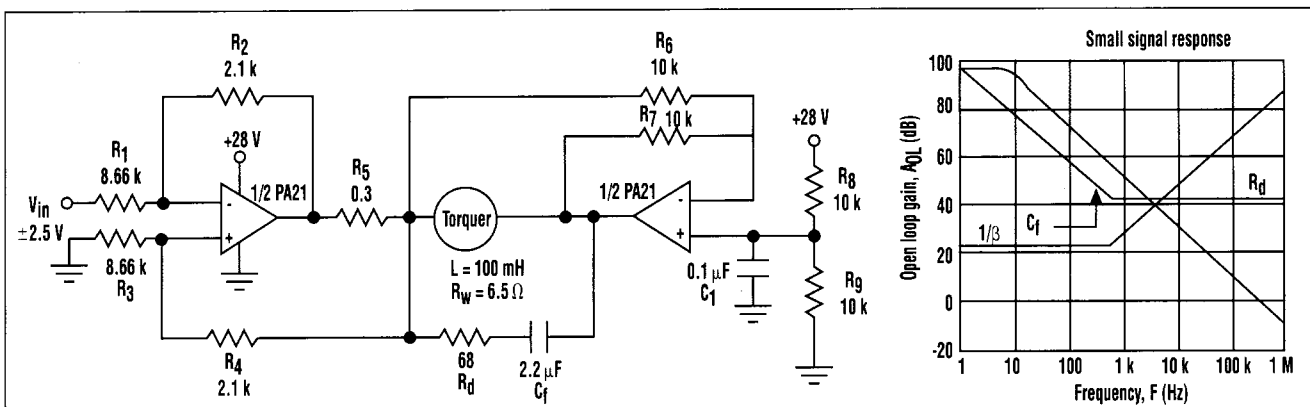

6. DRIVEN FROM A SINGLE power supply, two Improved-Howland circuits in a bridge configuration supply bidirectional drive for a torque motor.

pate some power. Inductance in these resistors will actually enhance stability, but will also trade off good dynamic performance.

A PRACTICAL HOWLAND

To illustrate a practical realization of the improved Howland circuit, observe the following example. A torque-motor driver must supply a ± 2 -A output from a ± 2.5 -V input (Fig. 6). The load is a torque motor with an inductance of 100 mH and a dc resistance of 6.5Ω . A bridge circuit is chosen to provide bidirectional drive using a single power supply.

The first and most subjective (these are the moments that separate analog engineers from all others) step in the design is selecting the desired value of the current-sense resistor (R_s). The object here is to optimize the trade-off between the greater losses incurred with a larger resistor, and the better bandwidth and accuracy that would be achieved. This low-voltage applica-

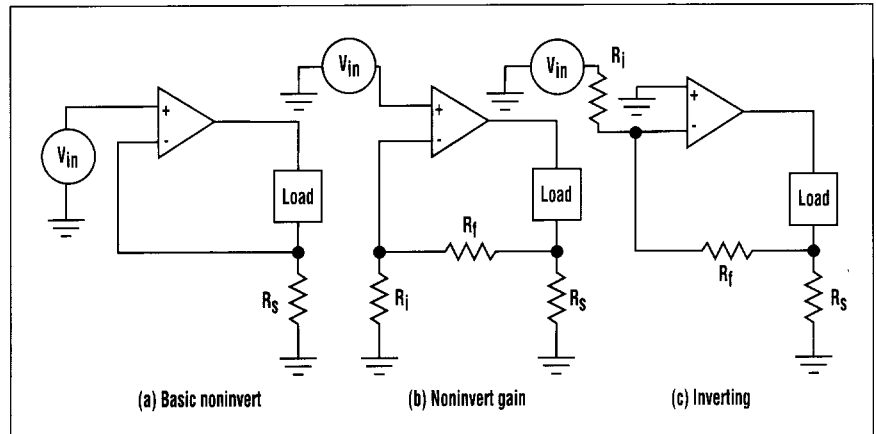

7. THE FLOATING-LOAD current-source topology can be configured three different ways: a basic noninverting circuit (a), noninverting with gain (b), and inverting with gain (c).

tion favors minimizing the value of R_s , therefore 0.3Ω is selected. The ratio of the feedback to the input resistors is then selected to provide the proper transfer function.

To analyze stability and arrive at proper compensation values, dc gain

is calculated per the methods and equations shown in Figure 3. This results in an equivalent dc gain ($1/\beta$ at dc) of 23 dB. Also, the inductive load causes a break frequency of approximately 1 kHz. The compensation resistor R_d is selected for a high frequency gain 20 dB greater than the dc gain, or 43 dB. Because this is a bridge with twice the effective voltage swing across R_d , its value is doubled to 68Ω . C_f is selected with R_d for a corner frequency of 1 kHz.

For the best possible accuracy, the floating-load current-source topology has far fewer components to affect accuracy and no matching requirements. The accuracy is directly related to the tolerance of the current-sense resistor

along with any op-amp errors. A CCCS can be realized with an inverting version of the floating-load current source.

With the basic floating-load current-source topology, the op amp simply forces the drop across resistor R_s to equal the applied input voltage (Fig. 7a). This results in the simple transfer function of V_{in}/R_s .

One variation on this circuit is the noninverting configuration with gain (Fig. 7b). Another alternative involves the inverting configuration (Fig. 7c). In the inverting case, raising gain is implicit, and the circuit has a noise gain of 2. Furthermore, accuracy is reduced due to the circuit's lower loop gain. The extra components needed also affect accuracy. However, the input resistor can be eliminated from the inverting configuration if the circuit is driven from a true current source.

While accuracy requirements and analysis are readily apparent for the floating-load current source, stability considerations require more effort. Resistive loads present no problems and probably won't require compensation. As with the Improved Howland, however, inductive loads aggravate stability problems.

The feedback analysis of the floating-load current source is simpler because the only feedback paths will be to the amplifier's inverting input. Thus, applying rate-of-closure techniques is a straightforward process.

In an example circuit (Fig. 8), the $1/\beta$ response of the simple inductor

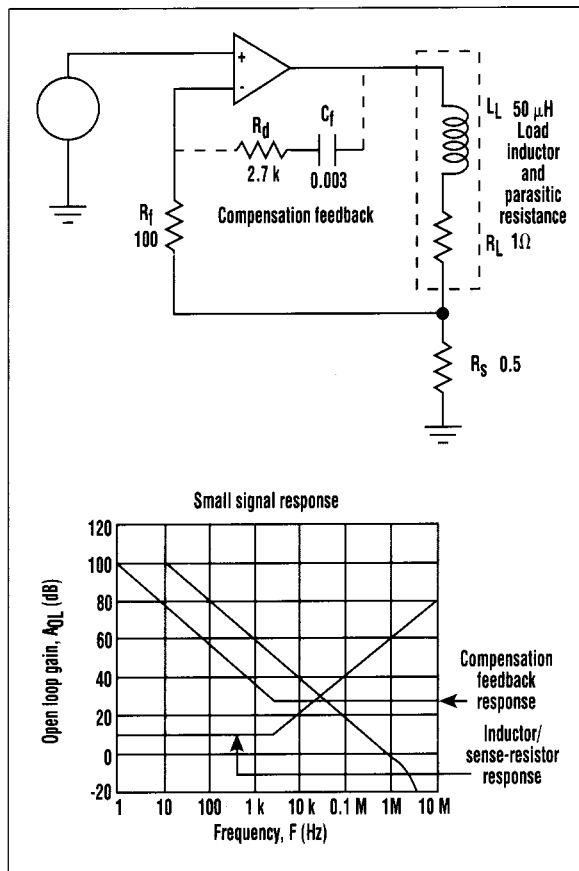

8. A SERIES combination of R_d and C_f compensates the floating-load current source. The ratio of R_d/R_f is chosen to yield a gain 20 dB greater than the circuit's dc gain.

and sense-resistor feedback will hereafter be referred to as the main feedback path, or feedback 1. Plotted on the amplifier A_{OL} graph, the response looks identical to the Howland circuit described earlier—with excessive phase shift.

To compensate the floating-load current source, add a compensation feedback path consisting of R_d and C_f . Use an additional resistor, R_f , to supply a ground-leg impedance for the compensation-feedback path. Select R_f to be a low value typically between 100 Ω and 1 k Ω .

Then, choose R_d so that the ratio R_d/R_f provides a gain 20 dB greater than the circuit's dc, or low-frequency gain. In addition, select C_f based on the value of R_d for a corner frequency less than or equal to the corner frequency of the main feedback path. When plotting the effect of multiple feedback paths, as shown in Figure 8, the path with a lower $1/\beta$ in decibels will be the dominant feedback path.

As in the case of the Howland circuit, these values will make it possible to construct a stable breadboard. But if maximum performance is demanded, such as in a high-speed deflection application, some tweaking will be necessary to obtain the fastest transitions. In general, raising R_d , and to a lesser extent, decreasing C_f , will improve transient performance. The ultimate limit is the point where the circuit begins to ring and eventually breaks into oscillation.

As with any current-output circuit operating into an inductive load, the fastest current transition is a function of $V = L \times (di/dt)$. This relationship defines the current slew rate of the circuit and is unrelated to, and generally slower than, the amplifier's voltage slew rate. The importance of this parameter is that designers often encounter ringing problems on fast transitions that can't be controlled by compensation. Usually, it's because they're applying a step-function input signal that's beyond the circuit's (not the amplifier's) ability to keep up. Keeping input transitions within the current-slew limitations of the circuit is essential in extracting the cleanest, fastest transitions.

Testing "intelligent" mains circuit

breakers calls for an accurate current source. These breakers are microprocessor-based devices that sense the very-high current found in ac mains systems. Sensing is accomplished with a current transformer that scales the current down to a maximum dynamic range of 20 A. Because the sensed current is from a current transformer rather than the ac mains, the compliance voltage is less than that of an ac line, and is typically less than 40 V.

These breakers—and remember they're complex microprocessor-based electronic systems—derive their power from the current transformer output (Fig. 9). When the output from the current transformer is adequate enough to develop a compliance voltage of at least 10 V, the breaker's input circuit uses that voltage to charge the processor power-supply capacitor and then close the shunt switch for current measurement. Whenever the processor power drops too low, the shunt switch is reopened long enough to recharge

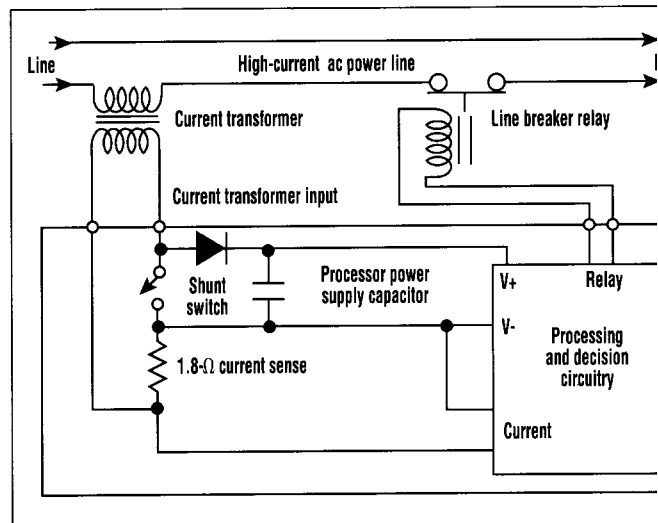

9. AN "INTELLIGENT" MAINS circuit breaker derives its power from the output of a current transformer. For testing purposes, the transformer is replaced with an accurate current-source circuit.

the power supply. The breakers act on the sensed current, via processing, to decide whether or not to open the line breaker relay.

The behavior of the breaker's power derivation circuitry causes it to act like a 1.8- Ω resistive load, with pulse interruptions into a rectifier-capacitor system. Luckily, the inductive components of this load are negligible, simplifying stability considerations. But current accuracy is very important, which is why the floating-load configuration is used.

These breakers are tested by driving them with precise, controlled amounts of current. This is accom-

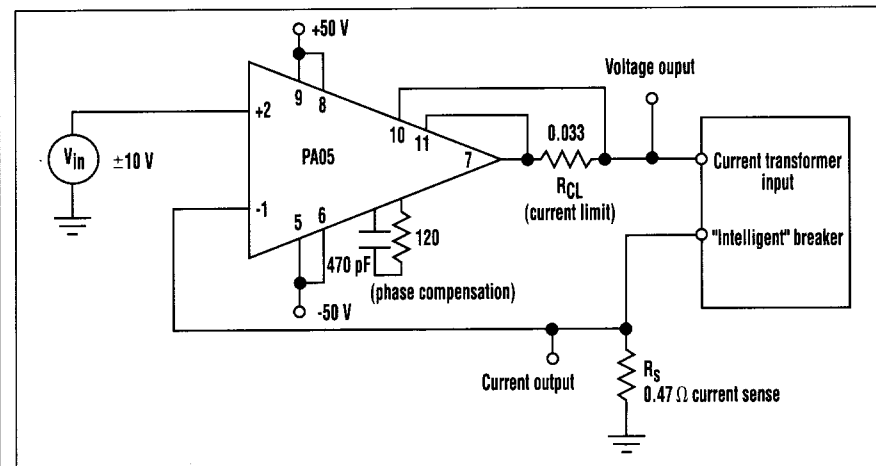

10. THIS TEST CIRCUIT for an "intelligent" mains circuit breaker illustrates a practical realization of the floating-load current source. With the components shown, the circuit delivers a 20-A peak output current with a 40-V peak compliance voltage.

plished by replacing the current transformer with a current-output amplifier circuit. The amplifier circuit must be capable of 20-A peak outputs and 40-V peak compliance voltage. Because the breaker input can float, it's possible to use the floating-load configuration and easily achieve the required high accuracy

(Fig. 10). To attain the required compliance voltage with room to spare, the amplifier must be able to operate on ± 50 -V supplies. The current requirement is addressed with the proper amplifier choice. In this example, the PA05 can supply up to 30 A from a thermally protected, current-limited, MOSFET output stage.

The amplifier can thus withstand load faults of any type, including complete shorts.

No compensation circuit is shown, nor needed. The reason is that the breakers simply don't have enough inductance to cause any stability problems. It's interesting to note that scope waveforms of the amplifier's voltage output show a sine wave with spikes. These spikes are caused by the breaker's internal power-derivation circuitry and its effect on output voltage compliance. But the waveform viewed across the 0.47- Ω current-sense resistor, which represents the actual current output, is a clean spike-free sine wave. This is indicative of accurate current forcing by the amplifier.

When actually working with, and taking measurements on, any current source, remember that the intent of the transfer function is current to voltage conversion. Examining an amplifier's output terminal with a scope only reveals incidental voltage behavior.

For example, when driving a brush-type dc motor, the commutation spikes are greatly exaggerated by the high, effective output impedance (certainly requiring proper fly-back-diode protection).

Looking at the Howland circuit's current output requires a differential-input scope connected across the current-sense resistor. Another alternative is using a scope with a current probe.

Another example involves sawtooth-scan deflection amplifiers. In this case, the amplifier's voltage output is an unsymmetrical square wave, while the current waveform is a faithful sawtooth. \square

Jerry Steele is employed as a senior applications engineer with Apex Microtechnology, and has 15 years of experience in electronic engineering, application engineering, and seminar presentations.

Tim Green, an applications engineer at Apex, holds a BSEE from the University of Arizona, Tucson.