

Operational Amplifier Basics

HISTORY

The performance and shape of operational amplifiers has changed considerably since the vacuum tube units were produced by George Philbrick, and others, over three decades ago. Discrete transistor-circuit op amps were the main catalog item for companies like Burr-Brown Research Corp. and Analog Devices. The monolithic age of high-production-volume op amps began with the uA709 from Fairchild. Modern op amps have taken on many signal processing challenges. The Apex Microtechnology family has been specialized for high power and high voltage. Whatever the specialty or construction technique, the underlying theory remains the same.

IDEAL MODEL

An ideal operational amplifier (modeled in Figure 1) is a voltage controlled voltage source. The input sense pins have infinite impedance to ground and to each other. The output source has a zero output impedance and the transfer constant (Open-loop Gain, A_{OL}) approaches infinity. This unit, simply placed in a system, would be of little use in a linear mode without the benefits of closed loop control in the form of negative feedback.

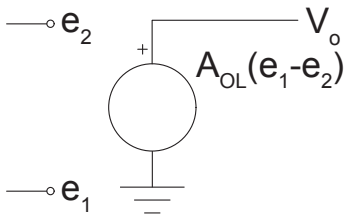

FIGURE 1. ELEMENTARY MODEL OF AN OPERATIONAL AMPLIFIER.

FEEDBACK CONTROL

Consider the circuit in Figure 2. For this first example, the op amp is placed in an inverting configuration with input resistor R_i and feedback resistor R_f . Since the op amp input impedance is infinite, all current flowing through R_i must flow through R_f .

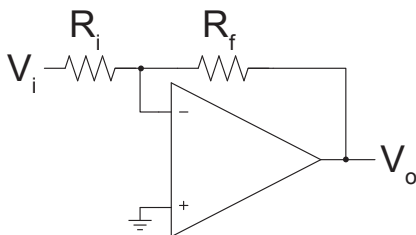

FIGURE 2. BASIC INVERTING CONFIGURATION.

If one writes the equations for current flow from V_i to V_o and solves for the V_i to V_o ratio the result is:

$$\frac{V_o}{V_i} = - \frac{R_f}{R_i}$$

Where: A_{OL} approaches infinity.

The operational amplifier has now been converted into a linear circuit element with significant possible extensions.

It is important to notice that the inverting input of the op amp (junction of R_i and R_f) is maintained very near to the potential of the non-inverting input. This point is a “summing junction” and is called a virtual ground. The op amp output is adjusting to maintain this relationship. This fact gives rise to two significant extensions. The input impedance is constant at the value of R_i and it is possible to have multiple inputs which are summed at the output. Each input may have a different gain associated with it as shown in Figure 3.

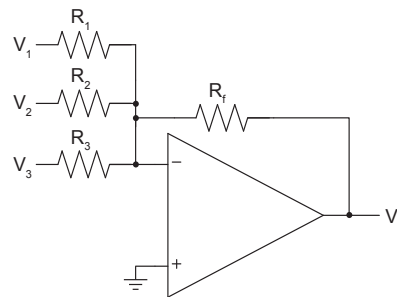

FIGURE 3. SUMMING AMPLIFIER CONNECTION.

The output of this configuration is given by the expression:

$$V_o = - R_f \left(\frac{V_1}{R_i} + \frac{V_2}{R_i} + \frac{V_3}{R_i} \right)$$

Our discussion up to here has ignored the non-inverting input. Write the current summation equations for the circuit in Figure 4 and solve for V_o in terms of V_i as above. With A_{OL} approaching infinity, the following relationship results.

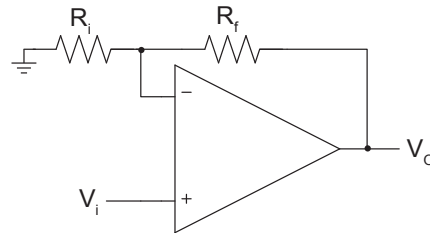

FIGURE 4. NON-INVERTING CONFIGURATION.

This circuit has the features that the output signal is not inverted as it is amplified, the input impedance approaches infinity, and the gain can not be less than unity.

$$V_o = V_i \left(1 + \frac{R_f}{R_i} \right)$$

By combining the inverting and non-inverting circuits it is possible to make a full, weighted sum and difference system element as shown in Figure 5.

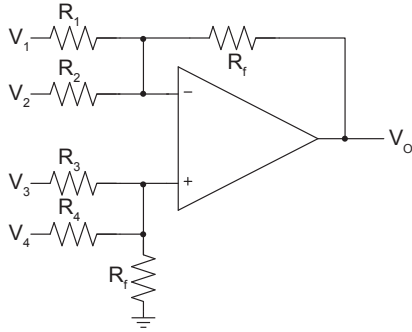

FIGURE 5. SUM AND DIFFERENCE AMPLIFIER.

Through the use of super-position the sum and difference amplifier can be analyzed. The accuracy of this relationship depends on the matching accuracy of the two resistors labeled R_f . The complete transfer function is given by:

$$V_o = R_f \left(-\frac{V_1}{R_1} - \frac{V_2}{R_2} + \frac{V_3}{R_3} + \frac{V_4}{R_4} \right)$$

NON-IDEAL OP AMPS

All of the discussion to this point has assumed an ideal device. With real world op amps there are deviations from the ideal, or errors. The magnitude of some of the possible errors for an op amp are listed in the specification sheet for that device. A description of the circuits used to measure these parameters can be found in the section titled "Parameter Definitions & Test Methods"

When the magnitude of the error, as seen at the output, is a direct function of the closed loop gain that error magnitude is specified referred to the input (RTI). The maximum error to be expected at the output is the error value times the non-inverting gain of the amplifier. The most common of these errors is initial voltage offset.

Recall that the op amp works because the negative feedback brings the inverting input to equal the non-inverting input. When connected as a non-inverting amplifier both inputs will be at a potential equal to the input signal. Since this input is common to both inputs it is called the "Common Mode Voltage." In an ideal amplifier the common mode signal would be subtracted out and not appear at the output. Due to limitations imposed by the real world circuits there is an error signal at the output which is a function of the common mode voltage. A limit exists on the range of the common mode voltage that the op amp can withstand.

POWER SUPPLY SYMMETRY

To this point we have not considered the power supply configuration. When op amps are furnished symmetric power supplies common mode voltage limits are easy to meet. It is generally possible to operate from a single supply if the common mode voltage limits are honored. For further extensions on single supply operation Application Note 21 should be studied.

AC CONSIDERATIONS

All of the relationships discussed above can be extended to the AC domain by replacing resistance with impedance and allowing for the finite frequency response of the op amp. If a plot is made of open loop gain vs frequency it would look similar to Figure 6. This graphic display is used to describe the op amp's open loop performance as a function of frequency and to predict stability.

The two change of slope points in the response curve are caused by the existence of poles in the transfer function of the op amp. Most op amps have Bode plots very similar to that shown in Figure 6. The slope of the trace between 10 Hz and 1 MHz is -20 dB per frequency decade. Extensive discussions of stability are presented in Application Note 19 and others. In the opening discussion we assumed the op amp gain to approach infinity. The difference between the open loop gain of the op amp and the closed loop gain, set by the feed-back network, is referred to as excess loop gain. As the excess loop gain decreases the op amp circuit deviates more from the ideal. Consider the op amp of Figure 6 if it were used in a closed loop gain configuration of 20 dB (X10) as shown by the dashed line. At low frequencies the excess loop gain is 80 dB. As the frequency is increased the excess loop gain decreases until it reaches zero dB at 100 KHz. The performance of the circuit would be very near ideal at low frequencies and deviate more from ideal as the frequency approached 100 KHz. If the closed loop gain was increased to 40dB(X100). The non-ideal response would become apparent one frequency decade earlier.

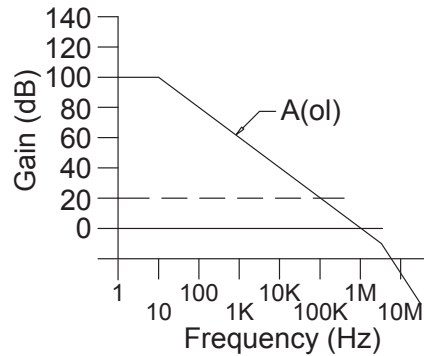

FIGURE 6. TYPICAL BODE PLOT.

CONCLUSION

Some of the basic features of operational amplifier circuits have been discussed here. The concept of negative feedback and the graphical representation of the Bode plot are the most common tools used in op amp circuit design. The application notes that follow present techniques for solving many of the problems which arise in the use of op amps.

NEED TECHNICAL HELP? CONTACT APEX SUPPORT!

For all Apex Microtechnology product questions and inquiries, call toll free 800-546-2739 in North America.

For inquiries via email, please contact apex.support@apexanalog.com.

International customers can also request support by contacting their local Apex Microtechnology Sales Representative.

To find the one nearest to you, go to www.apexanalog.com

IMPORTANT NOTICE

Apex Microtechnology, Inc. has made every effort to insure the accuracy of the content contained in this document. However, the information is subject to change without notice and is provided "AS IS" without warranty of any kind (expressed or implied). Apex Microtechnology reserves the right to make changes without further notice to any specifications or products mentioned herein to improve reliability. This document is the property of Apex Microtechnology and by furnishing this information, Apex Microtechnology grants no license, expressed or implied under any patents, mask work rights, copyrights, trademarks, trade secrets or other intellectual property rights. Apex Microtechnology owns the copyrights associated with the information contained herein and gives consent for copies to be made of the information only for use within your organization with respect to Apex Microtechnology integrated circuits or other products of Apex Microtechnology. This consent does not extend to other copying such as copying for general distribution, advertising or promotional purposes, or for creating any work for resale.

APEX MICRITECHNOLOGY PRODUCTS ARE NOT DESIGNED, AUTHORIZED OR WARRANTED TO BE SUITABLE FOR USE IN PRODUCTS USED FOR LIFE SUPPORT, AUTOMOTIVE SAFETY, SECURITY DEVICES, OR OTHER CRITICAL APPLICATIONS. PRODUCTS IN SUCH APPLICATIONS ARE UNDERSTOOD TO BE FULLY AT THE CUSTOMER OR THE CUSTOMER'S RISK.

Apex Microtechnology, Apex and Apex Precision Power are trademarks of Apex Microtechnology, Inc. All other corporate names noted herein may be trademarks of their respective holders.