

SOA Advantages of MOSFETs

NEW MOSFET POWER OP AMPS EASE SAFE OPERATING AREA LIMITATIONS

Hybrid power op amps continue to provide higher levels of performance and power handling than their monolithic counterparts. Power MOSFETs promise to continue the dominance of the hybrid power op amp in terms of power delivery and Safe Operating Area (SOA).

Protection issues must not be neglected regardless of amplifier choice, but the compromises required to protect the amplifier are eased with MOSFET designs. Protection of an amplifier is a matter of keeping it within its SOA under all expected conditions including faults such as short circuits.

An example of a common mistake in selecting an amplifier for a motor drive application is to use a 5A rated amplifier to drive a 1A motor. Specifying an amplifier for a motor drive application is not that simple, and stall or reversal conditions could overstress the amplifier.

Here is an illustration using a motor with the following specifications:

- Winding resistance: 1.24 ohms
- Voltage constant: 7.41V/K RPM
- Torque constant: 10oz/in/A

The actual running current depends on the required torque. Of most concern is the worst-case current requirements that occur under stall and acceleration conditions. Under stall conditions, the amplifier is presented with a load equal to the winding resistance of the motor. This condition must be within the SOA of the amplifier.

The motor's speed determines the applied voltage. If there are sudden reversals, the motor back EMF could theoretically reach a value equal to the full applied voltage or equal to the amplifiers supply rails. This would be equivalent to shorting the amplifier output to one of its supply rails with only the motor winding resistance in series.

While the MOSFET power op amps are often featured for their high speeds, motor drive applications can take advantage of the MOSFET SOA that is free from second breakdown. Second breakdown is a limitation of all bipolar output power op amps. Second breakdown severely limits an op amp's current capacity under conditions of high voltage stress. The MOSFET on the other hand is strictly limited by its power dissipation, or thermal limits. Figure 1 compares the 25°C SOA of the PA04 MOSFET amplifier with the bipolar PA03. While the PA03 is rated for higher currents and dissipation, the PA04 has greater current capacity when there is more than 110V stress on the output devices.

For 25°C SOA calculations with a MOSFET amplifier an SOA graph is not even necessary. As long as the product of voltage and current stress is within the power dissipation rating, the amplifier is safe. MOSFETs, to reiterate, are strictly power limited.

Proper selection of current limit will determine if an amplifier is safe under fault conditions. One way of viewing this limitation is to draw a graph of output voltage and current, and superimpose SOA limits as shown in Figure 2. This graph (PA04 and ±50V supplies shown) illustrates how greater currents are available

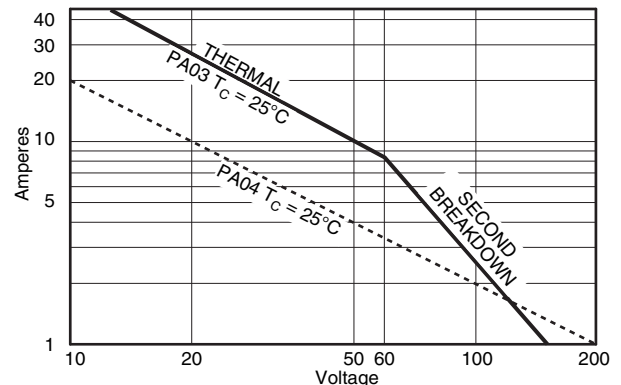

FIGURE 1. COMPARISON OF SOA FOR BIPOLAR (PA03) AND POWER MOSFET (PA04) POWER OP AMPS

when the output voltage swings closest to the rail supplying the current. The tradeoff occurs when setting current limits, usually for either of two fault conditions: shorts to ground or shorts to either supply rail. A stalled motor is equivalent to a short to ground through the motor winding resistance, while a reversal could assume the stresses of a short to either rail.

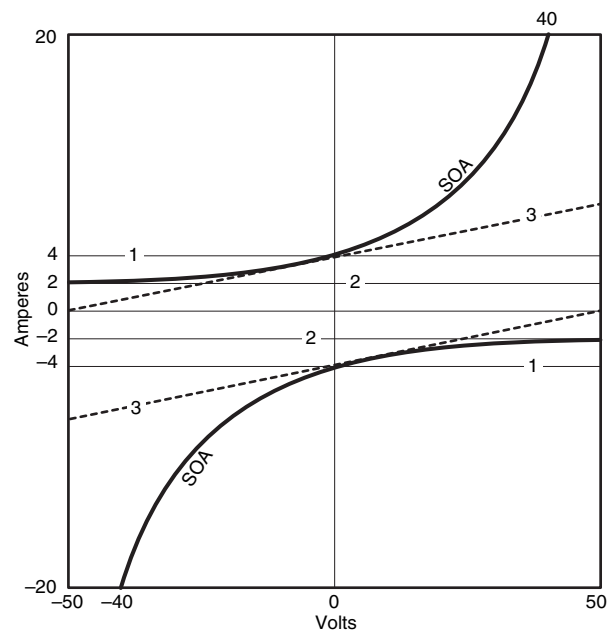

FIGURE 2. PLOT OF OUTPUT VOLTAGE AND CURRENT WITH SOA SUPERIMPOSED

From Figure 2, line 1, a limit safe for shorts to ground would be 4A (4A*50V=200W). This is well below the amplifier's full 20A capability. Even more stringent is the current limit for a short to either rail of 2A indicated by line 2 of Figure 2. A 2A limit, combined with external flyback diodes, would result in an amplifier tolerant of virtually any short or voltage kickback stress on its output. Keep in mind that this brief example uses as its basis, the 25°C SOA limits. In reality, internal dissipation and heatsinking limitations elevate temperatures, further reducing safe current levels.

FOLDOVER CURRENT LIMITING

The PA04 features four-wire current limit to overcome sensing errors occurring when working with such low resistances. While this four-wire current limit is useful in improving accuracy of current limit, it also facilitates implementing foldover current limiting. This limiting is known as load line limiting.

Foldover current limit allows more amplifier current as the output swings closer to the rail supplying the current shown by line 3 in Figure 2. Figure 3 shows the circuit to implement foldover current limiting. R_b and R_f configure a voltage divider that reduces the signal to the current limit transistors as the output swings closer to the current-supplying rail. R_f determines the slope of the foldover function. The value selected for R_b corresponds to the similar resistor internal to PA12 (actually 280 ohms) so that equations and methods developed for use with PA12 foldover limiting would be easily applied to PA04 external foldover limiting. The capacitor across R_b prevents stability problems while in current limit.

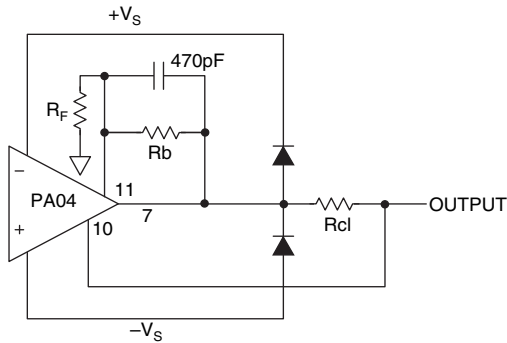

FIGURE 3. FOLDOVER CURRENT LIMITING CIRCUIT

The foldover slope must not be too steep, or latching may occur. This sets a limit to the value of R_f equal to $V_s/.0025$ which results in a foldover characteristic where current available when the voltage output has swung fully to the rail opposite to the one supplying current is zero. The current available when the output is closest to the rail supplying current is twice that available when the output is at zero volts. When using PA12 equations, substitute this value of R_f, in Kohms.

A PA04 incorporating foldover limiting at $\pm 50V$ and requiring safety for a short to ground, would have R_{CL} selected for a 4A limit (this presumes the amplifier case can be maintained at 25°C for the duration of the short, otherwise it would have to be reduced further to stay within temperature limitations). The foldover limiting would then allow 8A at full output swing, or near zero current when delivering current from the rail opposite the output voltage polarity. A bipolar amplifier such as PA12 would be limited to 3.2A under the same criteria. The most powerful monolithic would be limited to 300mA because it is configured only for simple single resistor current limiting.

SATURATION VOLTAGE AND BOOST PINS

In motor drive applications at lower voltages, the saturation voltage, described on the data sheet as *voltage swing*, the PA04 could result in considerable power dissipation. At 15A, the PA04 output can only swing to within 8.8 volts of the rail resulting in 132W of dissipation. Boost pins are provided on the PA04 to power the front-end of the amplifier on voltages higher than the output stage, thus improving saturation. Using these terminals reduces the swing-to-rail to 5.3V at 20A

for 106W dissipation. At 15A it is 4.7V for 60.5W dissipation.

Several methods can be used to supply the higher voltage required by the front-end. Additional power transformers, or additional taps on existing power transformers, or additional regulated supplies are obvious options. Modern voltage converter IC's make it inexpensive to develop these voltages under almost any condition. In Figure 4, zener regulated voltages are referred to each rail and provide power to Maxim voltage converter IC's to develop the boost potentials.

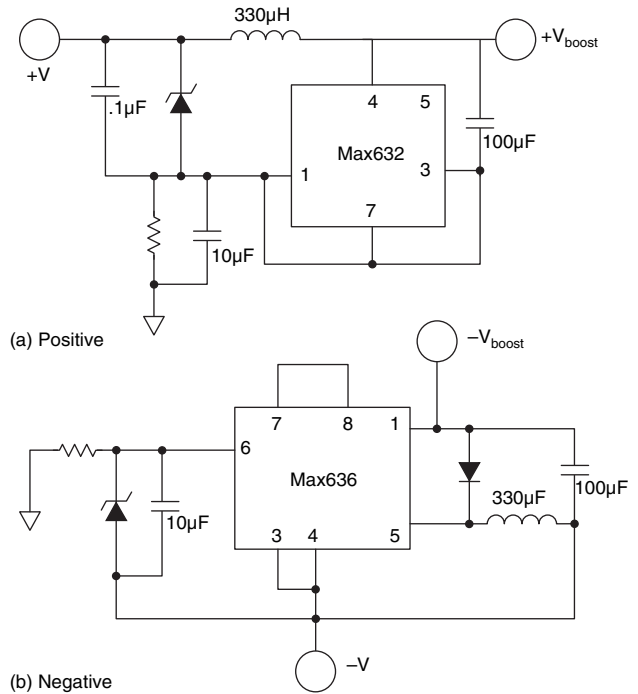

FIGURE 4. VOLTAGE BOOST CIRCUITS

MOSFET ADVANTAGES AT HIGHER VOLTAGES

The PA04 is rated at $\pm 100V$ or 200V rail-to-rail. This is twice the rating of any bipolar hybrid power op amp other than PA03, and 2.5 times the rating of any monolithic power op amp.

MOSFET's have made possible this increase in voltage ratings and this can be useful in motor drive applications at high voltages. Surprisingly, some DC motors require voltages around 100 volts. The PB50 power booster is a low-cost hybrid *buffer with gain* that gives the same ± 100 volt capability of PA04 with a maximum current of 2A. Because the PB50 is a MOSFET device, it can still provide 200mA at a full 200V stress.

An upgrade to the PB50 is the PB58 providing voltage capability up to ± 150 volts. While PB58 is rated 1.5A, the premium PB58A is specified up to 2A. A key advantage of PB58, especially for motor drives, is its 87W dissipation. Operated at $\pm 100V$, the PB58 can provide 435mA with complete safety. At $\pm 50V$, PB58 can deliver up to 870mA. This is well over twice what could be tolerated from an amplifier such as the PA12 under the same conditions, much less from monolithic power op amps.

Both PB50 and PB58 are power booster amplifiers, not stand alone op amps. Refer to PB50 and PB58 data sheets for typical examples of actual composite amplifier circuits.

Several alternatives are given. They range from low speed, high accuracy circuits, to high speed circuits.

ADVANCED AMPLIFIER PROTECTION

The PA04's adaptability to foldover current limiting is important but not the last word in protection. Prior efforts at SOA protection have been based on bipolar transistor designs sensing output transistor temperature combined with current limiting. These techniques have shortcomings when overstress occurs while operating in the second breakdown region of bipolar power devices. The isolated hot spot occurring during second breakdown can escape sensing by the temperature sensor.

For example, PA03 senses power transistor temperature to provide a high degree of protection. But at total rail-to-rail voltages in excess of 60V ($\pm 30V$), second breakdown still makes the amplifier prone to failure in extreme stresses.

In a MOSFET power output device, if a local hot spot occurs, the local transconductance decreases along with an increase in R_{ds} at the hot spot. This facilitates thermal spreading rather than concentrating heat. As a result thermal sensing should prove extremely effective with power MOSFET's. Apex Microtechnology is developing such amplifiers and early testing has shown that this may be the key to ultimate amplifier protection.

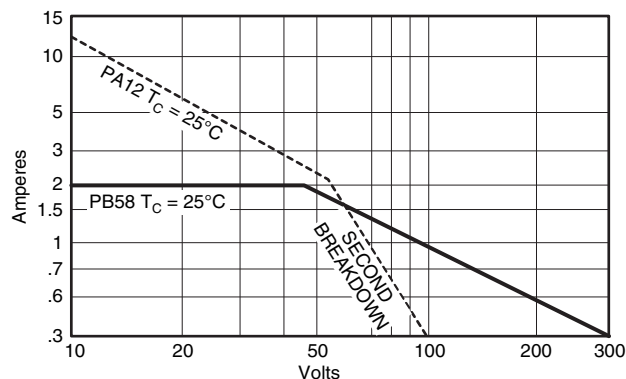

FIGURE 5. COMPARISON OF SOA FOR PA12 AND PB58

NEED TECHNICAL HELP? CONTACT APEX SUPPORT!

For all Apex Microtechnology product questions and inquiries, call toll free 800-546-2739 in North America.

For inquiries via email, please contact apex.support@apexanalog.com.

International customers can also request support by contacting their local Apex Microtechnology Sales Representative.

To find the one nearest to you, go to www.apexanalog.com

IMPORTANT NOTICE

Apex Microtechnology, Inc. has made every effort to insure the accuracy of the content contained in this document. However, the information is subject to change without notice and is provided "AS IS" without warranty of any kind (expressed or implied). Apex Microtechnology reserves the right to make changes without further notice to any specifications or products mentioned herein to improve reliability. This document is the property of Apex Microtechnology and by furnishing this information, Apex Microtechnology grants no license, expressed or implied under any patents, mask work rights, copyrights, trademarks, trade secrets or other intellectual property rights. Apex Microtechnology owns the copyrights associated with the information contained herein and gives consent for copies to be made of the information only for use within your organization with respect to Apex Microtechnology integrated circuits or other products of Apex Microtechnology. This consent does not extend to other copying such as copying for general distribution, advertising or promotional purposes, or for creating any work for resale.

APEX MICROTECHNOLOGY PRODUCTS ARE NOT DESIGNED, AUTHORIZED OR WARRANTED TO BE SUITABLE FOR USE IN PRODUCTS USED FOR LIFE SUPPORT, AUTOMOTIVE SAFETY, SECURITY DEVICES, OR OTHER CRITICAL APPLICATIONS. PRODUCTS IN SUCH APPLICATIONS ARE UNDERSTOOD TO BE FULLY AT THE CUSTOMER OR THE CUSTOMER'S RISK.

Apex Microtechnology, Apex and Apex Precision Power are trademarks of Apex Microtechnology, Inc. All other corporate names noted herein may be trademarks of their respective holders.