

Programmable Power Supplies

INTRODUCTION

The programmable power supply (PPS) is not only a key element in automated test equipment, but it is also used in fields as diverse as industrial controls, scientific research and vehicular controls. When coupled to a computer, it bridges the gap from the software to the control task at hand. This application note examines the basic operation of the PPS, the multitude of possible configurations and the key accuracy considerations.

VOLTAGE OUTPUT VERSIONS

The most basic and often most accurate version of the PPS requires only a current output Digital to Analog Converter (DAC), a power op amp and a feedback resistor as illustrated in Figure 1. According to op amp theory, the voltage at the inverting input (summing junction) will be zero and op amp input current will be zero. As a result, all current from the DAC flows through the feedback resistor R_F . Ohm's law then causes the circuit to provide a precise output voltage as function of DAC output current. Given a perfect DAC and feedback resistor, only two op amp parameters contribute significantly to the output voltage errors. These are voltage offset (V_{OS}), modeled by the battery, and bias current (I_B), represented by the current source. Due to the high output impedance of the current output DAC in relation to R_F , V_{OS} errors appear at the output without gain.

For a 10V output and op amp offset of 5mV, this error contributes only 0.05%. For a 100V output, a 0.5mV offset

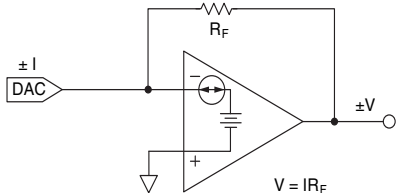

FIGURE 1. CURRENT TO VOLT CONVERSION

contributes an error of only 5ppm. Clearly, the DAC can easily be the major error source.

Op amp bias currents add to the DAC output current. The majority of available DAC's have full scale currents of ± 1 mA or 0/2mA. Most of today's bipolar input power op amps feature bias currents of less than 50nA. This results in errors of only 25 ppm maximum of the full scale range (FSR). FET input bias currents at 25°C are seldom over 100 pA and are specified as low as 10pA. These errors translate to 0.05ppm and 0.005 ppm. Since FET bias currents are generally characterized as doubling every 10°C, the bias current of the two examples could become 100nA and 10nA at 125°C, producing errors of 50ppm and 5.4ppm, respectively. Again, the DAC is the critical error source.

To determine the significance of the error contribution of a specific power op amp to the performance of various systems, refer to Table 1, next page. The least significant bit (LSB) is the value of the smallest step change of output. Comparing the calculated errors to the LSB values reveals system compatibility. For current output, DACs op amp bias currents compare directly with the DAC current LSB and V_{OS} errors compare directly with the full scale output voltage. Thus, the importance of low bias

currents is dependent solely on system resolution. However, the significance of voltage offset specifications varies with both resolution and full scale voltage range.

USING VOLTAGE OUTPUT DACS

When using a voltage output DAC, the power op amp can be added with either inverting or non-inverting gain to form the PPS. It usually costs more than implementation with a current output DAC, and has less accuracy. However, system or logistic factors may dictate the use of the voltage output DAC.

Figure 2 illustrates the basic inverting gain version and Figure 3 shows a non-inverting setup. Error calculations are still simple even though some new variables have been added. Voltage offset errors appear at the output multiplied by the gain of the circuit (A_V+1 for inverting circuits). To maximize accuracy, the highest output DAC's should be used with minimum voltage gains in the op amp configuration. When using ± 10 V DAC's, a direct V_{OS} to LSB comparison can be made using the 20V FSR values listed in Table 1. Also, bias currents flow through the feedback resistor producing output voltage errors; thus, values of R_F and R_{IN} are usually kept as low as possible.

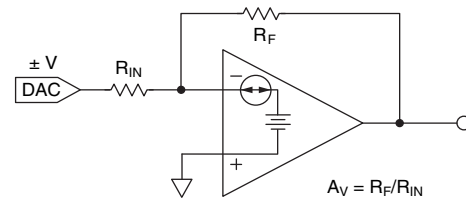

FIGURE 2. INVERTING VOLTAGE GAIN

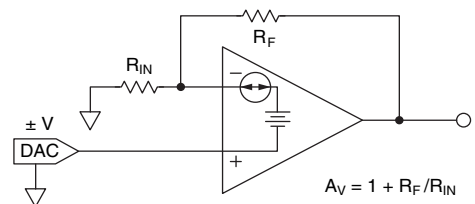

FIGURE 3. NON-INVERTING VOLTAGE GAIN

A CASE FOR REMOTE SENSING

The circuit of Figure 4 shows the wire resistance (R_W) from the power op amp to the load and back to the local ground via the power return line. A 5A load current across only 0.05Ω

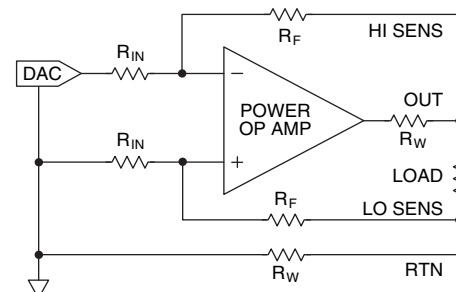

FIGURE 4. REMOTE SENSING PROGRAMMABLE POWER SUPPLY

in each line would produce a 0.5V IR drop. Without remote sensing, this would become an error at the load. With the addition of the second ratio matched R_F/R_{IN} pair and two low current sense wires, IR drops in the power return line become common mode voltages for which the op amp has a very high rejection ratio. Voltage drops in the output and power return wires are inside the feedback loop; therefore, as long as the power op amp has the voltage drive capability to overcome the IR losses, accuracy remains high.

CURRENT OUTPUT VERSIONS

A current output PPS using a current output DAC can be implemented as shown in Figure 5. Another version of the current output PPS is shown in Figure 6. This allows the load to be grounded, but is more complex and has additional errors. Especially if the output currents are relatively low, the current through the lower R_F/R_{IN} pair may become significant because it is also sensed by R_S . Major errors can be caused by ratio mismatching between the R_F/R_{IN} pairs. The resulting voltage errors across the sense resistor equal the output voltage times the ratio mismatch. For example, consider a 0.2Ω sense resistor, a 5A output requiring a 20V drive and a ratio mismatch of only 0.1% causes an error of 2%. Even an 8-bit LSB is only 0.39%!

In all of the current output circuits discussed, errors due to voltage offset appear across the sense resistor at a gain

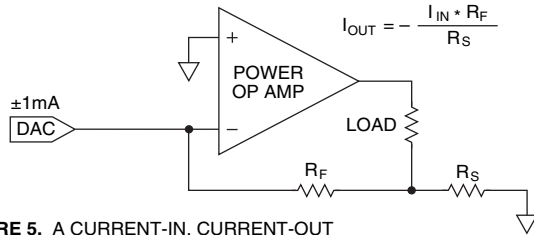

FIGURE 5. A CURRENT-IN, CURRENT-OUT PROGRAMMABLE POWER SUPPLY

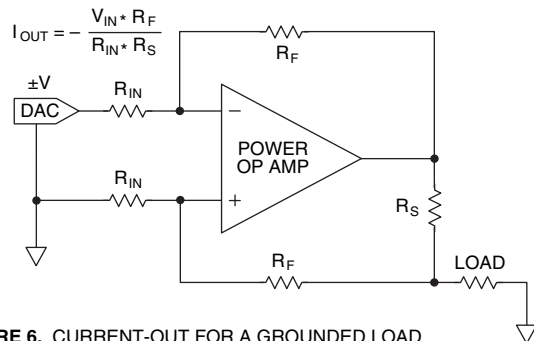

FIGURE 6. CURRENT-OUT FOR A GROUNDLED LOAD

of one or more. This means higher sense resistor values will minimize output current errors at the expense of increased power dissipation in R_S , the power op amp and system power supplies. One other word of caution, if the load contains inductive elements, refer to Applications Note 5 which discusses maintaining stability in precision current output circuits having reactive loads such as deflection coils. A current output PPS using a voltage output DAC is shown in Figure 7. The power op amp drives current through the load until voltage on the sense resistor (R_S) equals the input voltage. To achieve high efficiency (low voltage across R_S compared to the load voltage), this circuit requires a low voltage DAC or a high voltage op amp. If neither is possible, the circuit of Figure 8 allows the sense resistor voltage drop to be lower than the input voltage.

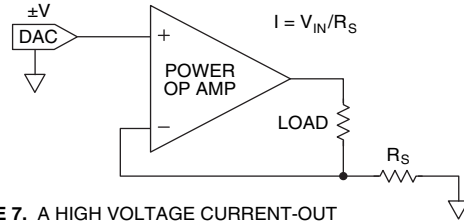

FIGURE 7. A HIGH VOLTAGE CURRENT-OUT PROGRAMMABLE SUPPLY

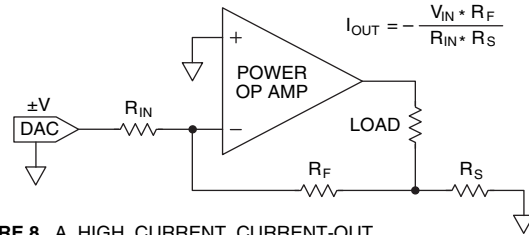

FIGURE 8. A HIGH CURRENT, CURRENT-OUT PROGRAMMABLE POWER SUPPLY

PROGRAMMABLE ACTIVE LOADS

To obtain the V-I characteristics of a power source, it may be desirable to control the output voltage and measure the output current or visa versa. The current output circuits shown are suitable as active current loads. The circuit of Figure 9 performs voltage loading of a solar cell panel. The power op amp forces the DAC voltage to appear across the panel and also performs an I to V conversion providing the data to plot V-I characteristics.

Due to its flexibility, accuracy and ease of use, the power op

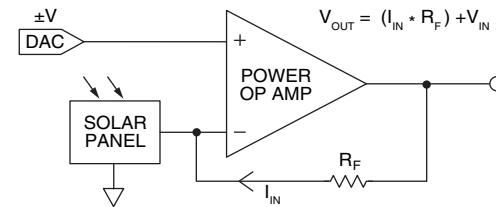

FIGURE 9. SOLAR PANEL TESTER

amp is the leading choice when programmable power supplies are called for. They greatly simplify circuits requiring unipolar outputs and are very cost effective when designing bipolar power supplies. The only remaining question is whether to buy the power op amp or to make one in discrete form. For low quantity production runs, the required design effort renders the “make” option too expensive. For high volume runs, the question is more involved. In many applications, the smaller size and lower weight plus high reliability, make the “buy” decision the only reasonable choice. (See “The Advantages of IC power op amps.”) In all applications, the hybrid power op amp enhances design quality, speeds assembly and reduces overhead costs.

FULL SCALE RANGE					
BITS	PPM	2mA	20V	50V	200V
8	3906	7.8µA	78mV	195mV	.78V
10	977	1.95µA	19.5mV	48.8mV	195mV
12	244	488nA	4.88mV	12.2mV	48.8mV
14	61	122nA	1.22mV	3.05mV	12.2mV
16	15.3	30.5nA	305µV	.763mV	3.05mV

TABLE 1. LSB VALUES FOR VARIOUS OUTPUT LEVELS

NEED TECHNICAL HELP? CONTACT APEX SUPPORT!

For all Apex Microtechnology product questions and inquiries, call toll free 800-546-2739 in North America.

For inquiries via email, please contact apex.support@apexanalog.com.

International customers can also request support by contacting their local Apex Microtechnology Sales Representative.

To find the one nearest to you, go to www.apexanalog.com

IMPORTANT NOTICE

Apex Microtechnology, Inc. has made every effort to insure the accuracy of the content contained in this document. However, the information is subject to change without notice and is provided "AS IS" without warranty of any kind (expressed or implied). Apex Microtechnology reserves the right to make changes without further notice to any specifications or products mentioned herein to improve reliability. This document is the property of Apex Microtechnology and by furnishing this information, Apex Microtechnology grants no license, expressed or implied under any patents, mask work rights, copyrights, trademarks, trade secrets or other intellectual property rights. Apex Microtechnology owns the copyrights associated with the information contained herein and gives consent for copies to be made of the information only for use within your organization with respect to Apex Microtechnology integrated circuits or other products of Apex Microtechnology. This consent does not extend to other copying such as copying for general distribution, advertising or promotional purposes, or for creating any work for resale.

APEX MICROT TECHNOLOGY PRODUCTS ARE NOT DESIGNED, AUTHORIZED OR WARRANTED TO BE SUITABLE FOR USE IN PRODUCTS USED FOR LIFE SUPPORT, AUTOMOTIVE SAFETY, SECURITY DEVICES, OR OTHER CRITICAL APPLICATIONS. PRODUCTS IN SUCH APPLICATIONS ARE UNDERSTOOD TO BE FULLY AT THE CUSTOMER OR THE CUSTOMER'S RISK.

Apex Microtechnology, Apex and Apex Precision Power are trademarks of Apex Microtechnology, Inc. All other corporate names noted herein may be trademarks of their respective holders.